

SPINNER

Servo-Load 80/110

Bar Loading Magazine for short bars



Highlights

Our high-performance automation peripheral

The Servo-Load 80/110 from SPINNER is the ideal and economic solution for automatic loading of bars with a diameter up to 110mm and a length up to 1.500mm. Our high-performance bar loader complements and is especially adapted to all SPINNER single and sub-spindle turning machines.

With a CNC controlled axis for the pusher our bar loader allows the feeding of bar material in short cycle times to a programmed distance without requiring any hard stop in the turret.

Thanks to a transverse sliding mechanism that is fixed to the floor, access to the lathe spindle is always possible when for example a reduction tube must be changed. In addition to that the precision alignment between the bar feeder and the lathe is still maintained after the reduction tube has been changed.

Servo-Load an TTC300



Also available with a spindle extension

MAIN ADVANTAGES AT A GLANCE

- 3 sizes are available (see: Technical data)
- Compact and thus low floor space requirement
- With servo-drive for a fast loading cycle time
- Precise bar separation and guidance technology
- Suitable for round and profile bars
- Including 3 pushers (6/12/18mm)
- Increases the productivity and profitability of your lathe
- Simple connection to the SPINNER lathe by optimised UNIMAG-interface





Simple and user-friendly control panel with touchscreen control

The touchscreen of the SPINNER Servo-Load 80 and 110 has clear menu navigation. This facilitates the interaction between the operator and the bar magazine.

Space requirement

(Dimensions in mm)

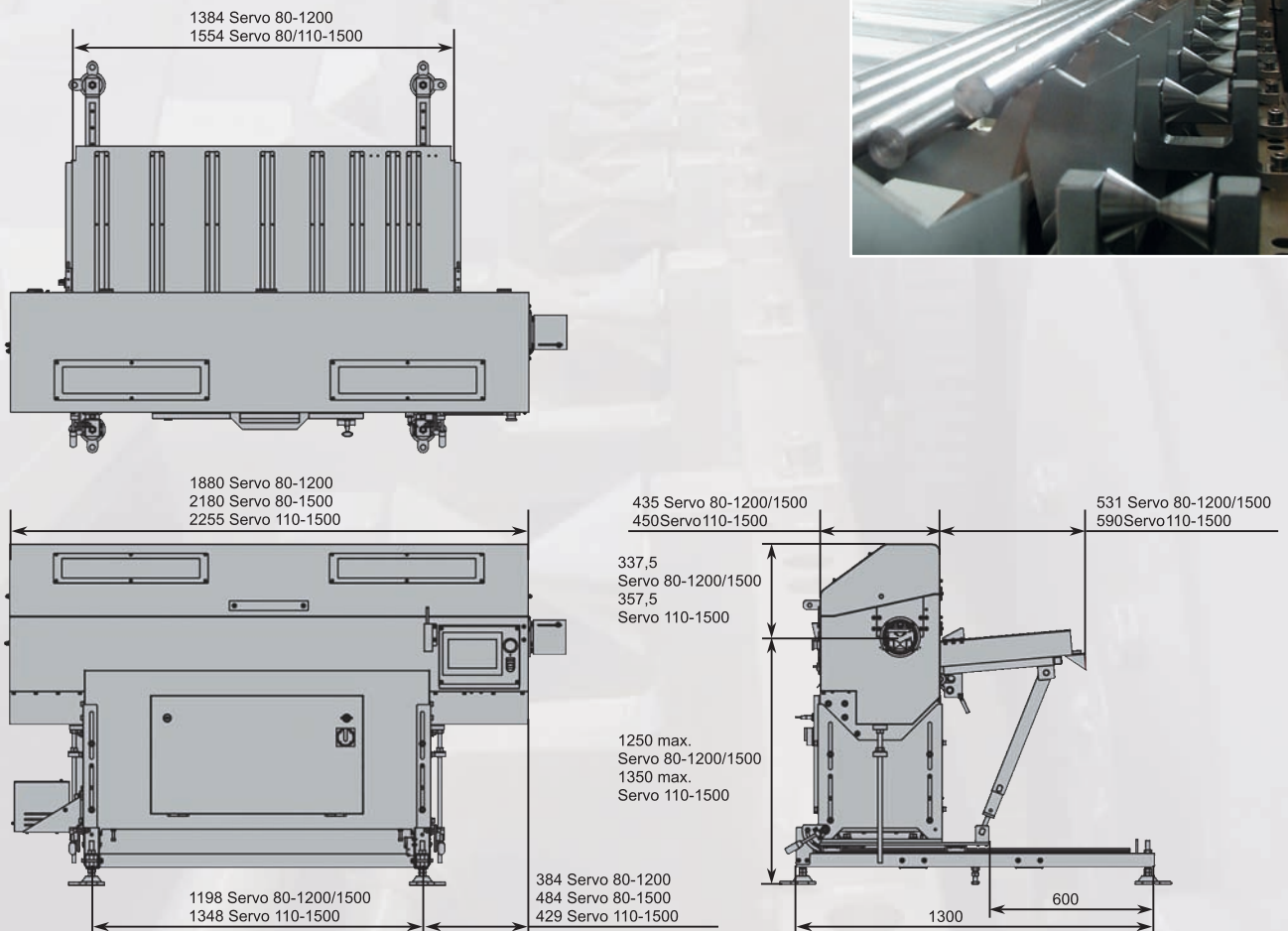

Technical data

	Servo 80-1200	Servo 80-1500	Servo 110-1500
Bar diameter	6 - 80 mm		10 - 110 mm
Bar length *)	700 - 1200 mm *)		700 - 1500 mm *)
Pusher	6 / 12 / 18 mm		
Max. bar weight	70 kg	70 kg	110 kg
Drive	Servo		

*) Depending on SPINNER machine model and spindle length



Werkzeugmaschinenfabrik GmbH



www.spinner.eu.com

Spinner Machine-Tools are working successfully world wide with many well known clients in more than 60 countries on 6 continents. We have been fortunate enough to attract small component suppliers in addition to well known global groups in all metal machining industries.

We have designed and produced the most modern machine-tools since 1950. More than 20.000 delivered machines demonstrate their high efficiency, precision and reliability, everyday.

Although Spinner is a medium-sized enterprise we produce and sell more than 1.000 CNC machines a year. And the number is increasing every year. Our company combines the know-how of a global player with the flexibility and cost-effective structures of a family owned business.

Place your trust in our products as well and let us know what we can do for you.



Video

SPINNER Werkzeugmaschinenfabrik GmbH

Rudolf-Diesel-Ring 24

82054 Sauerlach

Tel. +49 (0) 8104 803-0

Fax +49 (0) 8104 803-19

sales@spinner.eu.com



Version 05.04.2017 (GB)

Technical changes of specifications and pictures are subject to change without notice - Pictures can include options, accessories