



ORIGINAL OPERATING MANUAL

- Please keep for future reference -

Minimum Quantity Lubrication Applicator



1 Index

1	Index	2
2	General	4
2.1	About this operating manual	4
2.1.1	Revision status of the operating manual	4
2.1.2	Requirements for the operation of the applicator	4
2.1.3	Availability of the operating manual	4
2.2	Notes and symbols used in this operating manual	4
2.2.1	Instruction and results	4
2.2.2	Description of safety notes	4
2.2.3	Symbols	5
2.2.4	Notes	5
2.3	Name and address of manufacturer	6
2.4	Warranty and liability	6
2.5	Complementary documents	6
2.6	Product monitoring	6
2.7	Safety information	6
2.7.1	Conversions or modifications carried out by the user	6
2.7.2	Residual dangers	6
2.7.3	Personnel requirements	6
3	Technical description	6
3.1	Intended use	6
3.2	Reasonably foreseeable misuse	7
3.3	Functional description	8
3.4	Main Components	9
3.4.1	Applicator equipped with aluminium pump	9
3.4.2	Applicator equipped with brass pump	10
4	Technical Data	11
4.1	Dimensions and weights	11
4.2	Details of power and media supply	11
4.3	Specified lubricants	11
4.5	Further technical data	12
4.6	Emission of noise, waste etc.	12
4.7	Ambient conditions for operation and storage	12
4.8	Protection	12
4.8.1	Personal protective equipment	12
5	Preparation for use	13
5.1	Delivery	13
5.1.1	Delivery status	13
5.1.2	Standard scope of delivery	13
5.2	Transport and storage	13
5.2.1	Transport	13
5.2.2	Storage	13
5.3	Unpacking the ACCU-LUBE applicator	13
5.4	Check the delivery	14
5.5	Disposal of packaging material	14
6	Installation and mounting	14
6.1	Assembling the applicator	14
6.2	Mounting the applicator	15
6.2.1	Mounting with screws	15
6.2.2	Mounting with magnets (on ferrous surfaces)	16
6.3	Electric connection	17
6.3.1	Electric connection with 24 V DC (standard)	17
6.3.2	Electric connection with 110/230 V AC (Optional)	17

6.4	Pneumatic connection	17
6.5	Activation	18
7	Start-up and Settings	19
7.1	Filling in the lubricant	19
7.2	Adjusting the aluminium pump.....	20
7.3	Adjusting the brass pump	21
7.4	Adjusting the frequency generator	22
7.5	Adjusting the cycle by SPC.....	22
8	Normal operation	23
8.1	Refilling lubricant.....	23
8.2	Decommissioning the applicator.....	23
8.2.1	Shut down the applicator in an emergency	23
8.2.2	Short-term decommissioning of applicator	23
8.2.3	Long-term decommissioning of applicator.....	23
9	Maintenance	24
9.1	Safety measures during maintenance	24
9.2	Maintenance plan.....	24
9.3	Draining the air filter.....	24
10	Malfunctions	25
10.1	Trouble shooting	25
10.2	Removing bubbles from reservoir.....	25
11	Decommissioning and disposal of applicator	26
11.1	Final decommissioning of applicator.....	26
11.2	Disposal of applicator and operating materials.....	26
12	Accessories	27
13	List of spare parts and durables	28
13.1	Applicator with aluminium pump	28
13.2	Applicator with brass pump.....	30
13.3	Wiring schemes for the level indicator	32
14	EC Declaration of conformity	34
15	Index.....	35

2 General

2.1 About this operating manual

2.1.1 Revision status of the operating manual

Date of revision: 06.02.2017
Revision index: 00

2.1.2 Requirements for the operation of the applicator

We assume that

- The operating personnel has been briefed on the safe operation of the applicator and has read and understood the entire operating manual,
- The maintenance personnel service and repair the applicator in a way, that there is no risk from the applicator for humans, environment and material.

2.1.3 Availability of the operating manual

Operating manual is always to be kept available for all persons working with or on the applicator.

2.2 Notes and symbols used in this operating manual

2.2.1 Instruction and results

Instructions are marked in the order of their execution by triangles.
Results of the actions carried out are marked by a tick.

Example:

- ▶ Let the applicator operate until the lubricant level sinks.
- ✓ The brass pump will start supplying lubricant again.

2.2.2 Description of safety notes

Safety notes are always marked with a signal word and partially also with a hazard specific symbol (see chapter 2.2.3, page 5).

The following signal words or hazard levels are used:

⚠ DANGER!
Immediate danger! Failure to observe the safety notes might result in serious injuries or death!
⚠ WARNING!
Possibly dangerous situation! Failure to observe the safety notes might result in serious injuries or death!
⚠ CAUTION!
Possible dangerous situation! Failure to observe the safety notes might result in moderate to minor injuries!

ATTENTION!





Possibly dangerous situation!

Failure to observe the safety notes might result in material damage or environmental pollution!

2.2.3 Symbols





The following symbols are used in this operating manual and on the applicator:

Warnzeichen

	General Warning!
	Warning of dangerous, electrical voltages!
	Warning of substances hazardous to health or irritating substances!
	Warning of hot surfaces!
	Environmentally hazardous substance!

Tab. 1 Warning signals

Signs giving orders

	Follow operating manual!
	Wear safety goggles!
	Wear protective gloves!
	Disconnect before work!

Tab. 2 Signs giving orders

2.2.4 Notes

	Notes Describe general information and recommendations.
---	--

2.3 Name and address of manufacturer

Name	Accu-Lube Manufacturing GmbH
Address	Glaitstr. 29, D-75433 Maulbronn-Schmie
Phone	+49-7043-5612
E-mail	info@accu-lube.com
Internet	www.accu-lube.com

Tab. 3 Name and address of manufacturer

2.4 Warranty and liability

Basically the manufacturer's „general terms of sale and delivery“ will apply.

2.5 Complementary documents

Safety data sheets of ACCU-LUBE-lubricants can be downloaded from www.accu-lube.com.

2.6 Product monitoring

Manufacturers give information on

- accidents
- potential hazards of the applicator
- incomprehensibilities in this operating manual

2.7 Safety information

2.7.1 Conversions or modifications carried out by the user

Conversions or modifications on the applicator carried out by the user are not allowed and can lead to loss of EG-conformity!

2.7.2 Residual dangers

Residual dangers that might occur during operation, maintenance or repair, are dealt with in the respective chapters of this operating manual.

2.7.3 Personnel requirements

Only authorized persons may carry out work on the applicator! They must be familiar with the safety installations and regulations, prior to carrying out work. Authorised personnel is:

Operating stage	Qualifications required
Normal operation	Trained personnel
Cleaning	Trained personnel
Maintenance and repair	Trained personnel oft he operator or qualified personnel from the manufacturer
Repairs	Qualified personnel from the manufacturer

Tab. 4 Personnel requirements

3 Technical description

3.1 Intended use

The applicator must exclusively be used to atomise and supply lubricants for outside lubrication in the following processes:

- Cutting operations like sawing, drilling or milling
- Forming, stamping, bending
- Application of corrosion protection
- Assembly of components

Here only specified lubricants may be atomised and supplied.

The supply of compressed air without lubricant e.g. for blowing-out is allowed.

Depending on the requirements lubricant can also be supplied without compressed air.

- The applicator must be operated only within the specified performance limits (see technical data).
- The applicator must be operated only in industrial environment.
- Observing the operation manual and complying with the maintenance and servicing regulations is required for the intended use of the applicator.

3.2 Reasonably foreseeable misuse

Any other use beyond the intended use is considered as not intended use. The manufacturer does not assume liability for damages resulting from this. The manufacturer does not assume liability for modifications or improper installation, start-up, operation, maintenance or repair.

Only original parts supplied by the manufacturer are considered approved spare parts and accessories. Spare parts and accessories which have not been supplied by the manufacturer are not approved for operation and might affect operational safety. The manufacturer does not assume liability for damages caused by using non-approved spare parts and accessories.

Reasonably foreseeable misuse is in particular:

- Operation in explosive areas
- Operation in fire risk areas
- Operation beyond the specifications given by the manufacturer (e.g. higher pressures)
- Use of other than the specified lubricants
- Conversion or modification of the applicator without written consent of the manufacturer!

3.3 Functional description

Lubricant is supplied by the pump (2) from a reservoir (1) through a capillary hose to the nozzle.

Through the air flow (3) the lubricant is atomized at the nozzle (4) and applied to the tool.



Abb. 1 Functional description

3.4 Main Components

The applicator is available either with aluminium pumps (when operated with ACCU-LUBE lubricants) or with brass pumps (when operated with lubricants other than ACCU-LUBE).

3.4.1 Applicator equipped with aluminium pump

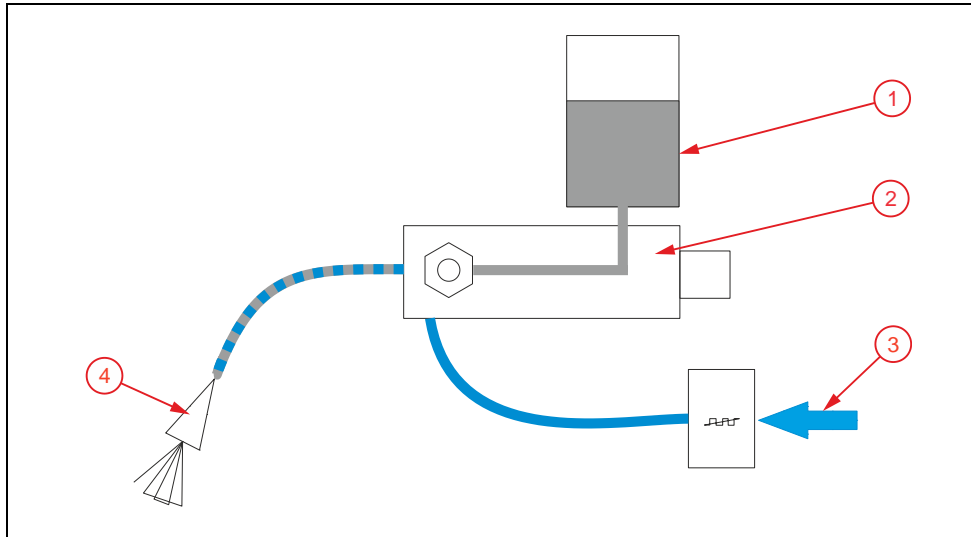

Abb. 2 Main components of the applicator equipped with an aluminium pump

Pos.	Components	Function
1	Connection for activation	Connection to provided control
2	Mounting system	Four bores for the mounting screws or alternatively for magnets
3	Connection for nozzle	Atomisation of the lubricant
4	Air flow valve	The air flow valve regulates the air output at the nozzle.
5	Reservoir	Reservoir for lubricant
6	Metal box	Housing of components
7	Adjusting knob	Regulation of lubricant volume
8	Connection for compressed air with air filter	Compressed air supply and elimination of moisture and impurities.
9	Actuator	Control of applicator
10	Frequency generator Standard: pneumatic Alternative: electronic	Sends air impulses to the pump.

Tab. 5 Main components and their function

3.4.2 Applicator equipped with brass pump

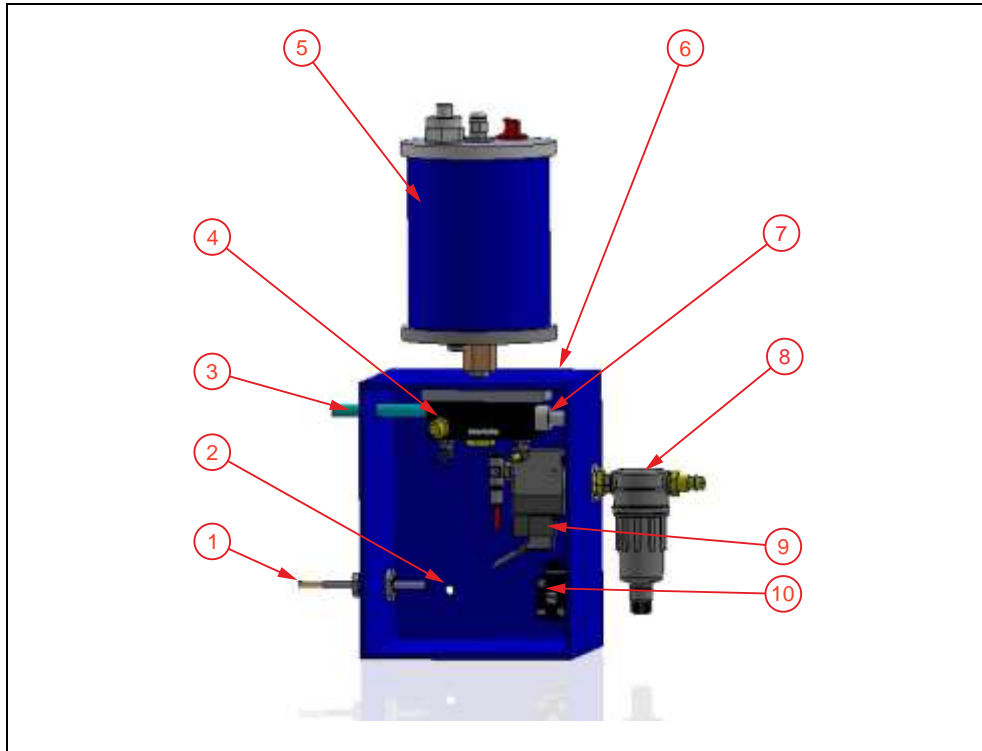

Abb. 3 Main components of the applicator equipped with a brass pump

Pos.	Components	Function
1	Connection for activation	Connection to provided control
2	Mounting system	Four bores for the mounting screws or alternatively for magnets
3	Connection for nozzle	Atomisation of the lubricant
4	Air flow valve	The air flow valve regulates the air output at the nozzle.
5	Reservoir	Reservoir for lubricant
6	Metal box	Housing of components
7	Adjusting knob	Regulation of lubricant volume
8	Connection for compressed air with air filter	Compressed air supply and elimination of moisture and impurities
9	Actuator	Control of applicator
10	Frequency generator Standard: pneumatic Alternative: electric	Sends air impulses to the pump.

Tab. 6 Main components and their function

4 Technical Data

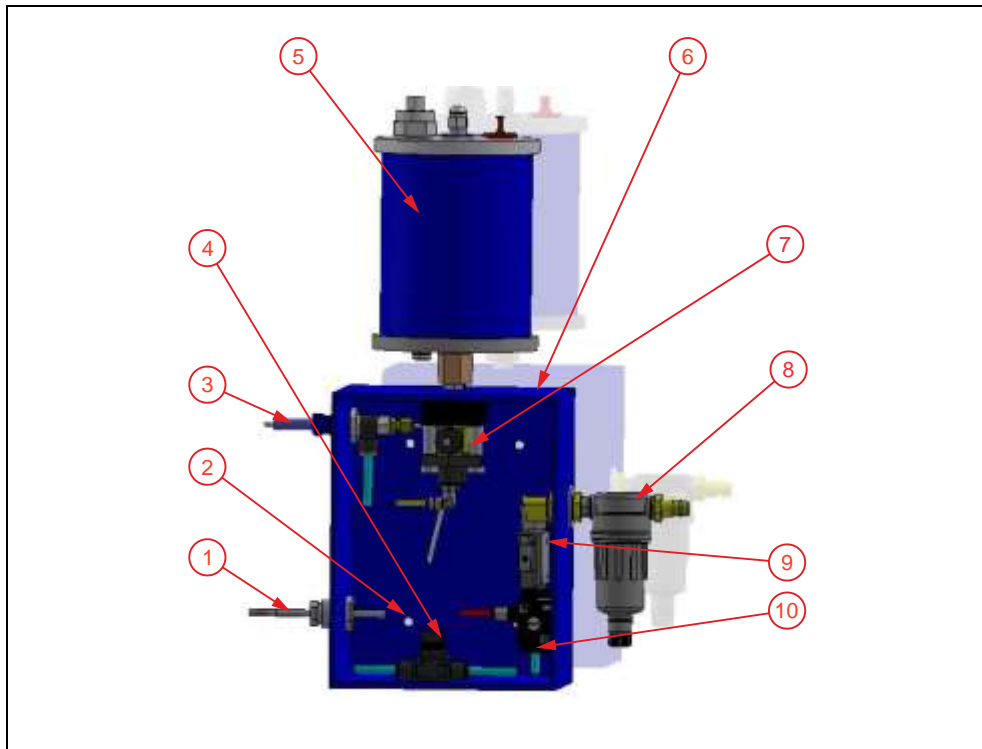
4.1 Dimensions and weights¹

Dimensions (L x W x H)	1 – 2 nozzles:	161 x 165 x 355 mm to 161 x 165 x 745 mm
	3 – 4 nozzles:	161 x 217 x 395 mm to 161 x 217 x 785 mm
	4 – 8 nozzles:	161 x 320 x 515 mm to 161 x 320 x 905 mm
Weight (empty)	≤ 30 kg	

4.2 Details of power and media supply

Electric	
Standard power supply	24 V DC
Alternative power supply	110 V AC, 230 V AC
Electrical power depending on model	3 VA
Pneumatic	
Compressed air connection	4,5 – 8 bar

4.3 Specified lubricants

Lubricants	Ingredients	Packaging units
LB 2000	Natural ingredients	1, 5, 20, 205 ltr.
LB 4000		
LB 4500		
LB 5000	Fatty alcohol	1, 5, 20, 205 ltr.
LB 5500		
LB 8000	Ester	1, 5, 20, 205 ltr.
LB 10000		

For further information please refer to the safety data sheets.

¹ The actual dimensions can vary depending on special configurations.

4.5 Further technical data

Frequency generator	
Pneumatic	5 – 200 strokes/min
Electric	1 – 120 strokes/min

Reservoir	
Volume	0,3 – 1,0 – 2,0 – 3,0 – 3,5 ltr.
Level indicator	To be selected

4.6 Emission of noise, waste etc.

Noise	
Sound pressure	< 70 dB(A)

4.7 Ambient conditions for operation and storage

Allowable ambient conditions	
Ambient temperature	0...+40°C
Installation site	Dry, frost-free
Atmosphere	Industrial environment, non-explosive

4.8 Protection

4.8.1 Personal protective equipment

Operation stage	Personal protective equipment
Normal operation	<ul style="list-style-type: none"> • Protective gloves
Cleaning	<ul style="list-style-type: none"> • Protective gloves
Maintenance and repair	<ul style="list-style-type: none"> • Protective gloves, protective shoes

Tab. 7 Personal protective equipment

5 Preparation for use

5.1 Delivery

5.1.1 Delivery status

The applicator is packed in bubble-wrap and delivered in a cardboard box padded with styrofoam.

5.1.2 Standard scope of delivery

Pos.	Components
1	Applicator with red plastic plug (top)
2	Reservoir
3	Air filter
4	Lubricant for start-up
5	Two keys for metal box

Tab. 8 Standard scope of delivery

Check completeness of delivery.

5.2 Transport and storage

⚠ CAUTION
<p>Risk of injury during transport! Applicator weighs up to 30 kg! ▶ Lift the applicator with two persons or use lifting gear.</p>

5.2.1 Transport

- ▶ Applicator is to be transported to the installation site with a suitable lifting gear. (Weight: see chapter 4, page 11)

5.2.2 Storage

Store in dry, frost protected places with corrosion-free atmosphere.

Allowable ambient conditions	
Ambient temperature	0...+30°C
Relative air moisture	max. 50%
Installation site	In-doors, even, dry, vibration-free
Atmosphere	Non-corrosive, non-explosive, non-flammable

Tab. 9 Allowable ambient conditions for storage

- ▶ Used or contaminated applicator is to be cleaned and drained completely before storage.
- ▶ For long term storage (> 2 years) applicator is to be protected against corrosion.

5.3 Unpacking the ACCU-LUBE applicator

- ▶ Open cardboard box and remove the packing material.
- ▶ Take out the applicator (avoid damages).

5.4 Check the delivery

- ▶ Check completeness of delivery (see chapter 5.1.2, page 13).
- ▶ If any components are missing inform the manufacturer immediately.
- ▶ Check the delivery for transport damage.
- ▶ If there is any transport damage inform forwarding agent immediately.

5.5 Disposal of packaging material

- ▶ Separate packaging material and dispose of environmentally sound.

6 Installation and mounting

⚠ WARNING!

Risk of injury with incorrect mounting!

- ▶ First mount the applicator safely!
- ▶ After safe mounting begin with start-up.

6.1 Assembling the applicator



Abb. 4 Assembling the applicator

- ▶ Screw-out red plastic plug on the top of the applicator.
- ▶ Check the thread.
- ▶ Screw-in the reservoir.
- ▶ Screw-in the air filter by hand.

6.2 Mounting the applicator

	<p>Select the installation site so that:</p> <ul style="list-style-type: none"> • The applicator is mounted level, • There is easy access to the reservoir for refilling.
---	---

6.2.1 Mounting with screws



Abb. 5 Mounting the applicator with screws

- ▶ Mount the applicator horizontally with 4 screws through the bores (1) on the rear side.
- ▶ Make sure the applicator is fixed properly.

6.2.2 Mounting with magnets (on ferrous surfaces)

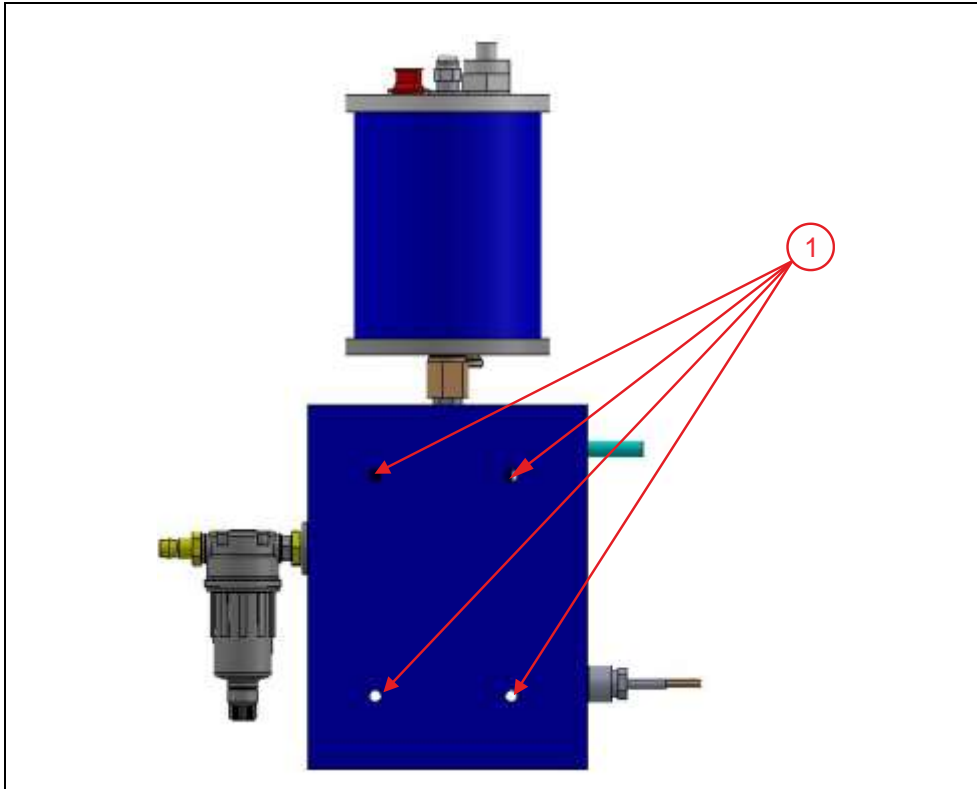

Abb. 6 Mounting the applicator with magnets

Mounting the applicator with magnets is possible only if the applicator is not moved during operation.

- ▶ Chose suitable magnets.
- ▶ Fix the magnets through the 4 bores (2) on the rear side.
- ▶ Mount the applicator on a suitable ferrous surface.
- ▶ Mount the applicator horizontally.
- ▶ Make sure the applicator is fixed properly.

6.3 Electric connection

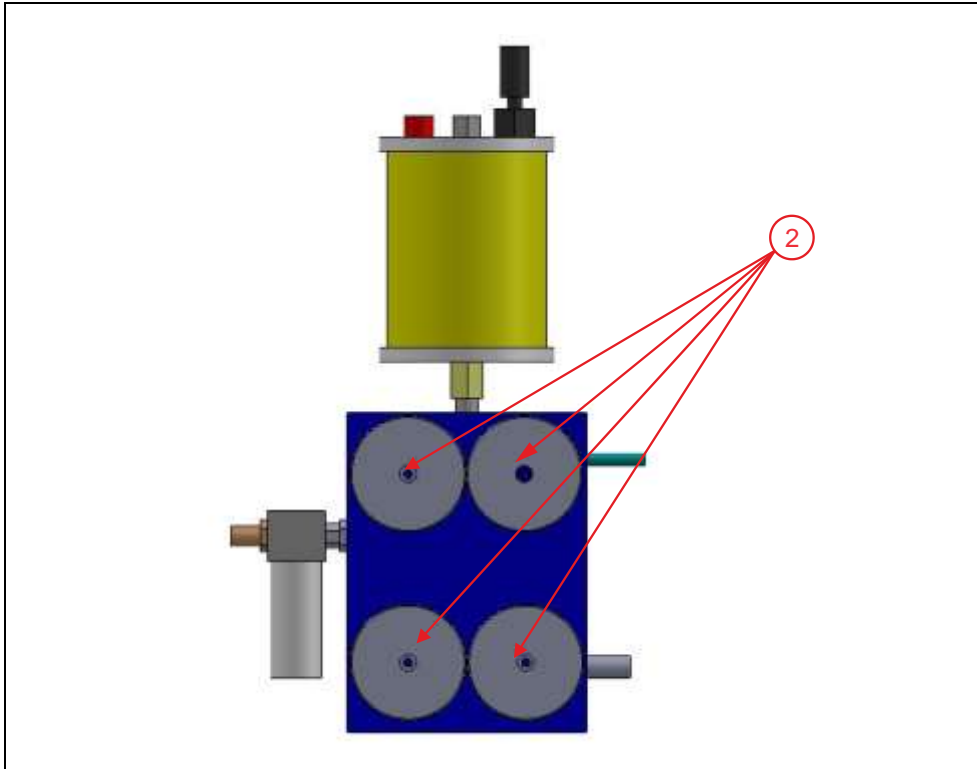
6.3.1 Electric connection with 24 V DC (standard)

- ▶ Adapt the included connecting cable to the on-site conditions.
- ▶ Lay connecting cable in suitable cable protection duct.
- ▶ Connect to 24 V DC (the wires can be connected either to „+“ or to „-“).





Abb. 7 Electrical connection 24 V DC

6.3.2 Electric connection with 110/230 V AC (Optional)

⚠ DANGER!	
	<p>Danger from electric voltage!</p> <ul style="list-style-type: none"> ▶ Before any work is carried out on electric installation: Disconnect from power supply! ▶ Work on the electric installation to be carried out by qualified electrician! ▶ Connect electrical earthing to the earth of the complete machine.

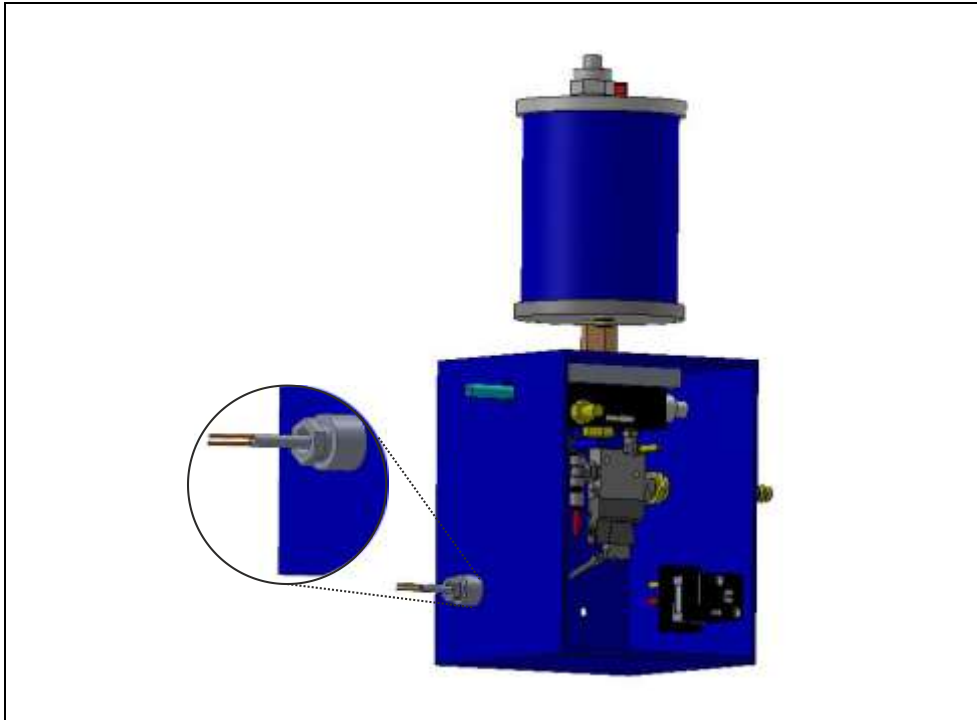
6.4 Pneumatic connection

ATTENTION!	
<p>Material damage caused by compressed air containing oil! Through compressed air containing oil components can be polluted or damaged.</p> <ul style="list-style-type: none"> ▶ When using compressed air containing oil install an oil filter! 	

The connection for the compressed air on the right hand side of the metal housing is standard on all applicators.



Abb. 8 Pneumatic connection

- ▶ Connect compressed air (see chapter 4.2, page 11).
- ▶ Drain air filter.

6.5 Activation

There are different types of actuators for an applicator:

- Solenoid valve
- Toggle switch
- Roller valve
- Hand sliding valve
- Foot pedal
- Air-actuated

7 Start-up and Settings

7.1 Filling in the lubricant

⚠ WARNING!

Danger of fire, explosion or injury caused by unsuitable lubricants or coolants!

- ▶ Only use approved, non-oxidising lubricants, which do not create an explosive atmosphere.
- ▶ Refilling only to be carried out by trained personnel.
- ▶ Wear suitable personal protective equipment.
- ▶ Read safety data sheets.

ATTENTION!

Material damage caused by unsuitable lubricants or coolants!

Only operate with ACCU-LUBE lubricants. Not specified lubricants might destroy the seals.

- ▶ Open the filling screw (1) on the reservoir.
 - ▶ Fill in lubricant.
 - ▶ Close the filling screw (1).
- ✓ The applicator is ready for operation.



Abb. 9 Filling in the lubricant

7.2 Adjusting the aluminium pump

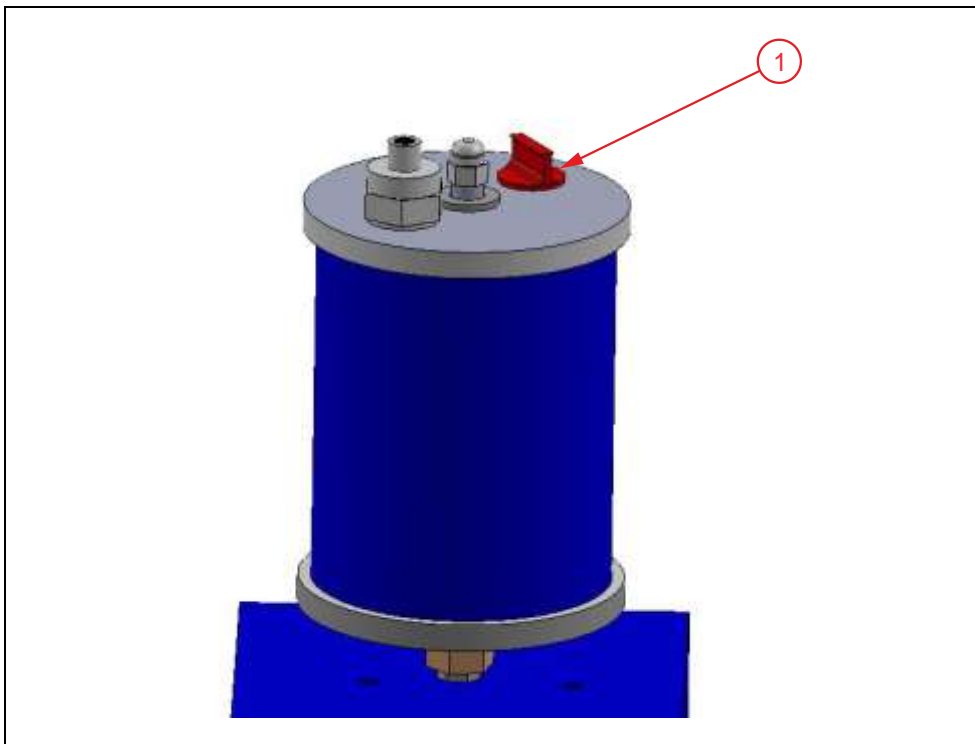

Abb. 10 Adjusting the aluminium pump

Adjusting the volume of lubricant

- ▶ Reduce lubricant volume: Turn adjusting screw (1) clockwise.
- ▶ Increase lubricant volume: Turn adjusting screw(1) anti clockwise.
- ▶ Standard setting: Turn adjusting screw (1) fully to the right, then open 2,5 revolutions.

Adjusting the volume of air

The air flow valve regulates the volume of air, that disperses the droplets of lubricant.

- ▶ Reduce air flow: turn air flow valve (2) clockwise.
- ▶ Increase air flow: turn air flow valve (2) anti clockwise.



Abb. 11 Fitting the capillary hose

Fitting the capillary hose

- ▶ Push the capillary hose (1) through the hose barb (2).
- ▶ Fit the O-ring (3) onto the capillary hose, so that 10 mm of the hose will still look out of the aluminium pump .
- ▶ Screw the hose barb into the aluminium pump.

7.3 Adjusting the brass pump

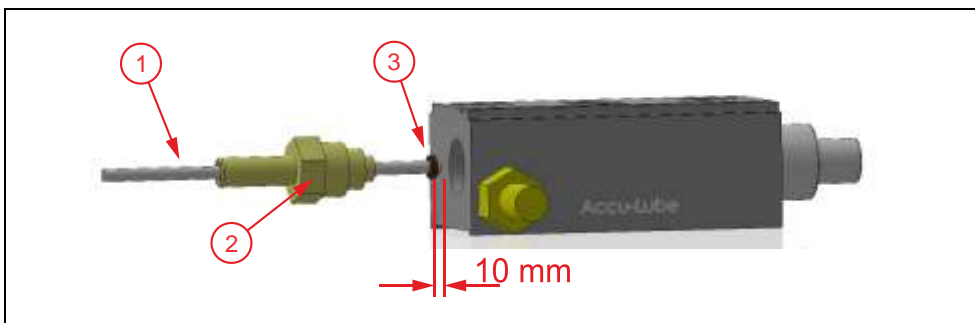

Abb. 12 Adjusting the brass pump

Adjusting the volume of lubricant

- ▶ Pull out adjusting knob (1)
- ▶ Reduce lubricant volume: turn adjusting knob (1) anti-clockwise.
- ▶ Increase lubricant volume: turn adjusting knob (1) clockwise.
- ▶ Standard setting: turn adjusting knob (1) clockwise to MAX-position, then turn back 38 clicks anti-clockwise.
- ▶ Push in adjusting knob (1) again..

7.4 Adjusting the frequency generator

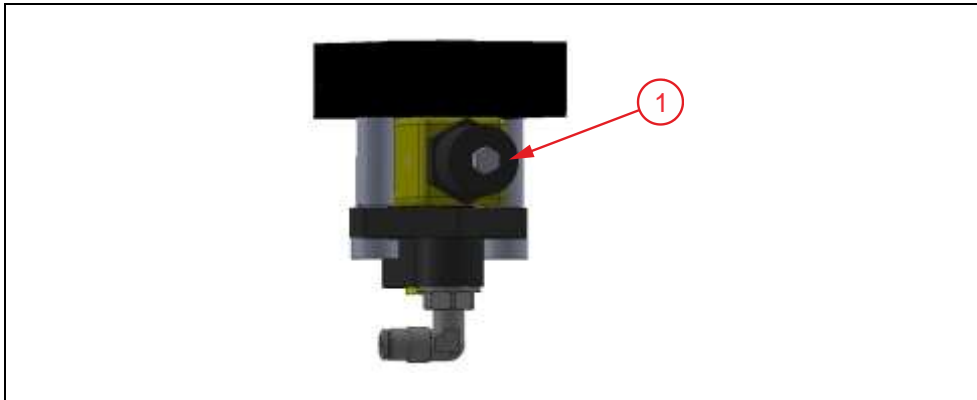
The frequency generator sends an air impulse to the aluminium- or brass pump, so that the set lubricant volume is supplied for a certain time.

The air impulse moves the piston in the pump forward. After the venting a spring will move the piston back into its initial position.

Pneumatic frequency generator



Abb. 13 Adjusting the pneumatic frequency generator

- ▶ Reduce cycle: Turn adjusting screw clockwise.
- ▶ Increase cycle: Turn adjusting screw anti-clockwise.
- ▶ Standard setting: Turn adjusting screw to 1,5.
- ▶ Switch off frequency generator: Turn adjusting screw to 0.

7.5 Adjusting the cycle by SPC

If the cycle is to be adjusted by stored program control (SPC), the pneumatic frequency generator must be replaced by a suitable solenoid valve.

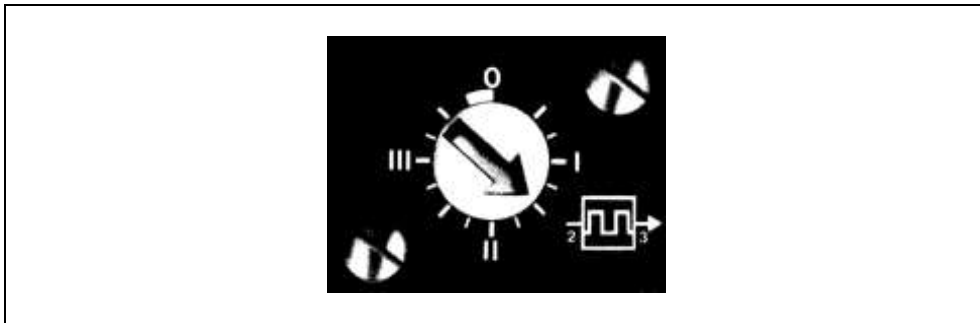
Basic setting of frequency: 13 impulses in 60 seconds.

8 Normal operation

In normal operation the applicator is operated according to the respective control (see chapter 6.5, page 18)

8.1 Refilling lubricant

⚠ WARNING!

Danger of fire, explosion or injury caused by unsuitable lubricants or coolants!

- ▶ Only use approved, non-oxidising lubricants, which do not create an explosive atmosphere.
- ▶ Refilling only to be carried out by trained personnel.
- ▶ Wear suitable personal protective equipment.
- ▶ Read safety data sheets.

ATTENTION!

Material damage caused by unsuitable lubricants or coolants!

Only operate with ACCU-LUBE lubricants. Not specified lubricants might destroy the seals.

Refilling is possible during operation.

- ▶ Open the filling screw on the reservoir.
- ▶ Fill in lubricant.
- ▶ Close the filling screw.

8.2 Decommissioning the applicator

8.2.1 Shut down the applicator in an emergency

Stop air supply with the emergency stop function of the machine, into which the applicator is integrated.

8.2.2 Short-term decommissioning of applicator

Stop the activation of the solenoid valve through the machine, into which the applicator is integrated.

8.2.3 Long-term decommissioning of applicator



Notes:

- ▶ After long-term decommissioning carry out start-up again.
- ▶ For storage longer than two years take corrosion protection measures.

- ▶ Decommission applicator (see above).
- ▶ Disconnect compressed air supply.
- ▶ Drain reservoir.
- ▶ Clean external parts with soapy water (pumps and hoses need not be cleaned).
- ▶ Store in a dry place.

9 Maintenance

9.1 Safety measures during maintenance

⚠ WARNING!
<p>Risk of injury during maintenance procedures!</p> <ul style="list-style-type: none"> ▶ Before carrying out maintenance procedures close down the higher-level machine. ▶ Secure the applicator against unauthorized restarting. ▶ Observe applicable accident prevention regulations and safety rules. ▶ Wear personal protective equipment (protective gloves).



Abb. 14 Secure the applicator against unauthorized restarting

9.2 Maintenance plan

Interval	Component	Action
If required	Air filter	Drain
	(Magnetic) Mounting	Check
	Nozzles	Check, replace if necessary
	Hoses, connecting lines	Check, replace if necessary
	Area below the applicator	Check for spilt lubricant, if necessary leak detection and sealing

Tab. 10 Maintenance plan

9.3 Draining the air filter

- ▶ Depressurize applicator.
- ▶ Disconnect from compressed air.
- ▶ Open drain screw.
- ▶ Drain water into a container.
- ▶ Close drain screw.
- ▶ Re-connect to compressed air.

10 Malfunctions

In case of queries please contact the manufacturer:

Name	Accu-Lube Manufacturing GmbH
Address	Glaitstr. 29, D-75433 Maulbronn-Schmie
Phone	+49-7043-5612
E-mail	info@accu-lube.com
Internet	www.accu-lube.com

Tab. 11 Contact data

Clients abroad please contact our distributors:

<http://www.accu-lube.com/kontakt/vertriebspartner/>

10.1 Trouble shooting

Case of trouble	Possible cause	Possible procedure
No lubricant on the cutting edge of the tool	Compressed air interrupted	▶ Check compressed air supply
	Hoses or lines defective	▶ Check hoses and lines
	Pump closed	▶ Check pump setting. ▶ If necessary re-adjust the pump.
	Defective pump	▶ Check pump, replace it if necessary.
	Bubbles in the reservoir	▶ Vent reservoir (see chapter 10.2, page 25)
Frequency generator does not cycle	Frequency setting on „0“	▶ Check and adjust frequency
	Compressed air interrupted	▶ Check compressed air supply
	Defective hoses	▶ Check hoses

Tab. 12 Trouble shooting

10.2 Removing bubbles from reservoir

Brass pumps must be operated without any bubbles.

- ▶ Depressurise applicator.
- ▶ Screw-off reservoir carefully.
- ▶ Turn adjusting knob clockwise to MAX-position.
- ▶ Fill the inlet of the brass pump with lubricant.
- ▶ Switch-on applicator without reservoir.
- ▶ Let the brass pump operate until the lubricant level sinks.
- ✓ The brass pump will start supplying lubricant again.
- ▶ Switch-off applicator.
- ▶ Screw-on reservoir.
- ▶ Re-adjust the adjusting knob to the desired setting.
- ▶ Re-connect to compressed air supply.

	Note: The aluminium pump normally is self-venting.
---	---

11 Decommissioning and disposal of applicator

11.1 Final decommissioning of applicator

⚠ WARNING!
<p>Risk of injury by unqualified dismantling e.g. by</p> <ul style="list-style-type: none"> • Unbriefed personnel • Dangerous residual materials • Stored (electric) energy • Breaks during dismantling. <p>▶ Dismantling only by qualified personnel. ▶ Wear suitable personal protective equipment. ▶ Appropriate disposal of components and residual materials!</p>

- ▶ Switch off applicator.
- ▶ Disconnect power supply from higher-level control cabinet by qualified electrician.
- ▶ Switch off and disconnect compressed air supply.
- ▶ Empty lubricant carefully and dispose of it appropriately.

11.2 Disposal of applicator and operating materials

⚠ WARNING!
<p>Risk of injury by unqualified disposal e.g. by</p> <ul style="list-style-type: none"> • Unbriefed personnel • Dangerous residual materials <p>▶ Disposal only by briefed personnel. ▶ Wear suitable personal protective equipment. ▶ Appropriate disposal of components and residual materials!</p>

- ▶ Assign qualified personnel.
- ▶ Wear personal protective equipment.
- ▶ Empty residual materials carefully and dispose of them appropriately.

Liquids	
Lubricants	Environmentally compatible disposal as special waste
Cleaning media	Environmentally compatible disposal as special waste
Applicator	
Wires, electric components	Disposal as electronic waste
Mechanical components	Sorted disposal

Tab. 13 Disposal

12 Accessories

Type	Accessories	Item-no.
Hose	PVC-hose	800 530
	Oil hose	800 515
	Metal protected hose	800 510
Nozzles	Loc-line nozzle 300 mm	800 966
	Loc-line nozzle 450 mm	800 954
	Loc-line nozzle 600 mm	800 958
	Flexible metal spray nozzle 320 mm	800 943
	Flexible metal spray nozzle 400 mm	800 942
	Copper nozzle 150 mm w/connecting parts	802 032
	Copper nozzle 300 mm w/connecting parts	802 035
	Copper nozzle 450 mm w/connecting parts	802 038
	Copper nozzle 600 mm w/connecting parts	802 043
	Steel nozzle 150 mm w/connecting parts	802 046
	Steel nozzle 300 mm w/connecting parts	802 047
	Steel nozzle 450 mm w/connecting parts	802 048
	Steel nozzle 600 mm w/connecting parts	802 044
	Nozzle for bandsaws with a width of 13 to 25 mm	802 120
	Nozzle for bandsaws with a width of 27 to 34 mm	802 125
	Nozzle for bandsaws with a width of 19 to 25 mm	802 110
	Nozzle for bandsaws with a width of 34 to 41 mm	802 127
	Nozzle for bandsaws with a width of 41 to 54 mm	802 130
	Nozzle for bandsaws with a width of 54 to 67 mm	802 132
	Nozzle for circular saws	802 135
Miniature nozzle	802 255	
Mounting block	Single with screws and nuts	801 175
	Double with screws and nuts	801 170
Nozzle tips for copper- and steel nozzles	Wide angle nozzle tip	800 980
	Standard nozzle tip \varnothing 3 mm	800 981
	Point nozzle tip \varnothing 1,5 mm	800 982

Tab. 14 Accessories

13 List of spare parts and durables

13.1 Applicator with aluminium pump



Abb. 15 Spare parts for applicator with aluminium pump

Pos.	Qty.	Description	Item-no.
1	1	Reservoir 0,3 litre	800 715
1	1	Reservoir 0,5 litre	800 686
1	1	Reservoir 1,0 litre	800 655
1	1	Reservoir 2,0 litre	800 660
1	1	Reservoir 3,0 litre	800 665
1	1	Reservoir 1,0 litre suitable for level indicator	800 725
1	1	Reservoir 2,0 litre suitable for level indicator	800 730
1	1	Reservoir 3,5 litre suitable for level indicator	800 740
2	1	Adapter plate for aluminium pump	804 018
3	1	Aluminium pump	804 000
4	1	Screw-in/plug-in/elbow piece	800 315
5	1	Solenoid valve 24 V	800 123
6	1	Bulkhead fitting	800 235
7	1	Coupling ¼"	800 001
8	1	Air filter	800 800
9	1	Washer	800 933
10	1	Plug with wire	800 122
11	1	Frequency generator	800 095
12	1	High-strength cable gland	
13	1	Connecting cable for control system	
14	1	Festo-hose red 4,0	800 023
15	1	Reduction PL 6-4	800 620
16	1	T-piece	800 770
17	1	Festo hose yellow 4,0	800 022
18	1	Festo hose blue 6,0	800 026
19	1	Plug for aluminium pump	804 055
20	1	Screw-in/plug-in/elbow piece	801 690
21	1	Hose barb for aluminium pump	800 506
22	1	Level indicator closer type	
22	1	Level indicator opener type	
24	1	Plug for level indicator	801 235

Tab. 15 Spare parts for applicator with aluminium pump

13.2 Applicator with brass pump

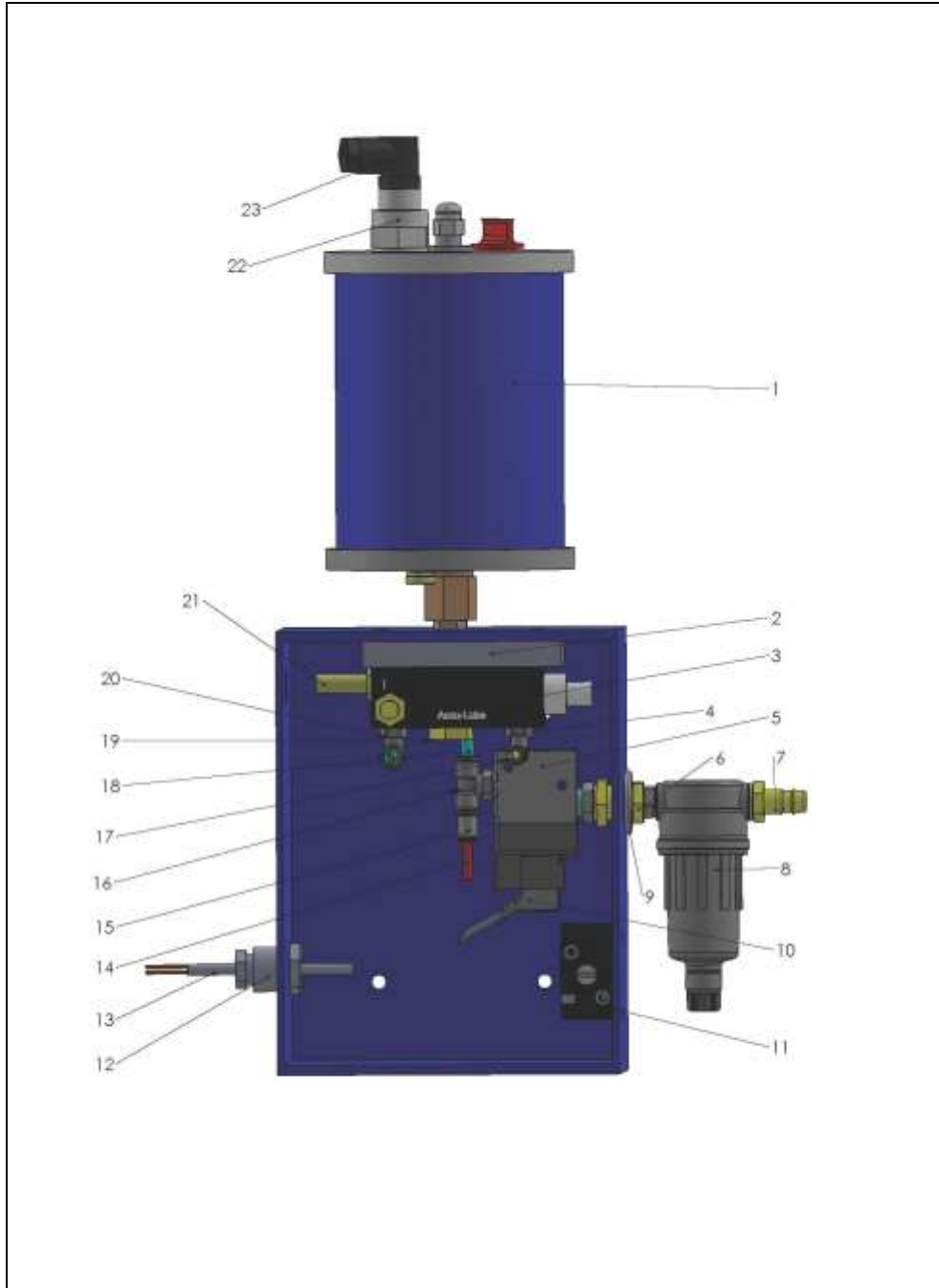

Abb. 16 Spare parts for applicator with brass pump

Pos.	Qty.	Description	Item-no.
1	1	Reservoir 0,3 litre	800 715
1	1	Reservoir 0,5 litre	800 686
1	1	Reservoir 1,0 litre	800 655
1	1	Reservoir 2,0 litre	800 660
1	1	Reservoir 3,0 litre	800 665
1	1	Reservoir 1,0 litre suitable for level indicator	800 725
1	1	Reservoir 2,0 litre suitable for level indicator	800 730
1	1	Reservoir 3,5 litre suitable for level indicator	800 740
2	1	Brass pump	800 080
3	1	Washer	800 932
4	1	Bulkhead fitting	800 235
5	1	Reducing fitting ¼"	800 790
6	1	Plug connection ¼"	800 001
7	1	Air filter	800 800
8	1	Inside / outside	800 866
9	1	Solenoid valve CPE14-M1BH, 24 V	800 123
10	1	Plug with wire	800 122
11	1	Frequency generator	800 099
12	1	Reduction 6-4	800 620
13	1	Festo-hose red PL 4	800 523
14	1	Festo-hose PL 6	800 526
15	1	Air flow valve	800 180
16	1	High-strength cable gland	801 700
17	1	Connecting cable for control system	
18	1	Oil hose	800 515
19	1	Festo-hose yellow PL 4	800 522
20	1	Screw-in/ plug-in/elbow piece	800 320
21	1	Ermeto-fitting	800 440
22	1	T-piece 1/8" IIA (inside, inside)	800 270
23	1	Reduction G3/8"-G1/8"	800 255
24	1	Festo-hose PL 8x6	800 540
25	1	Festo-fitting	800 473
26	1	Level indicator closer type	
26	1	Level indicator opener type	
27	1	Plug for level indicator	801 235

Tab. 16 Spare parts for applicator with brass pump

13.3 Wiring schemes for the level indicator

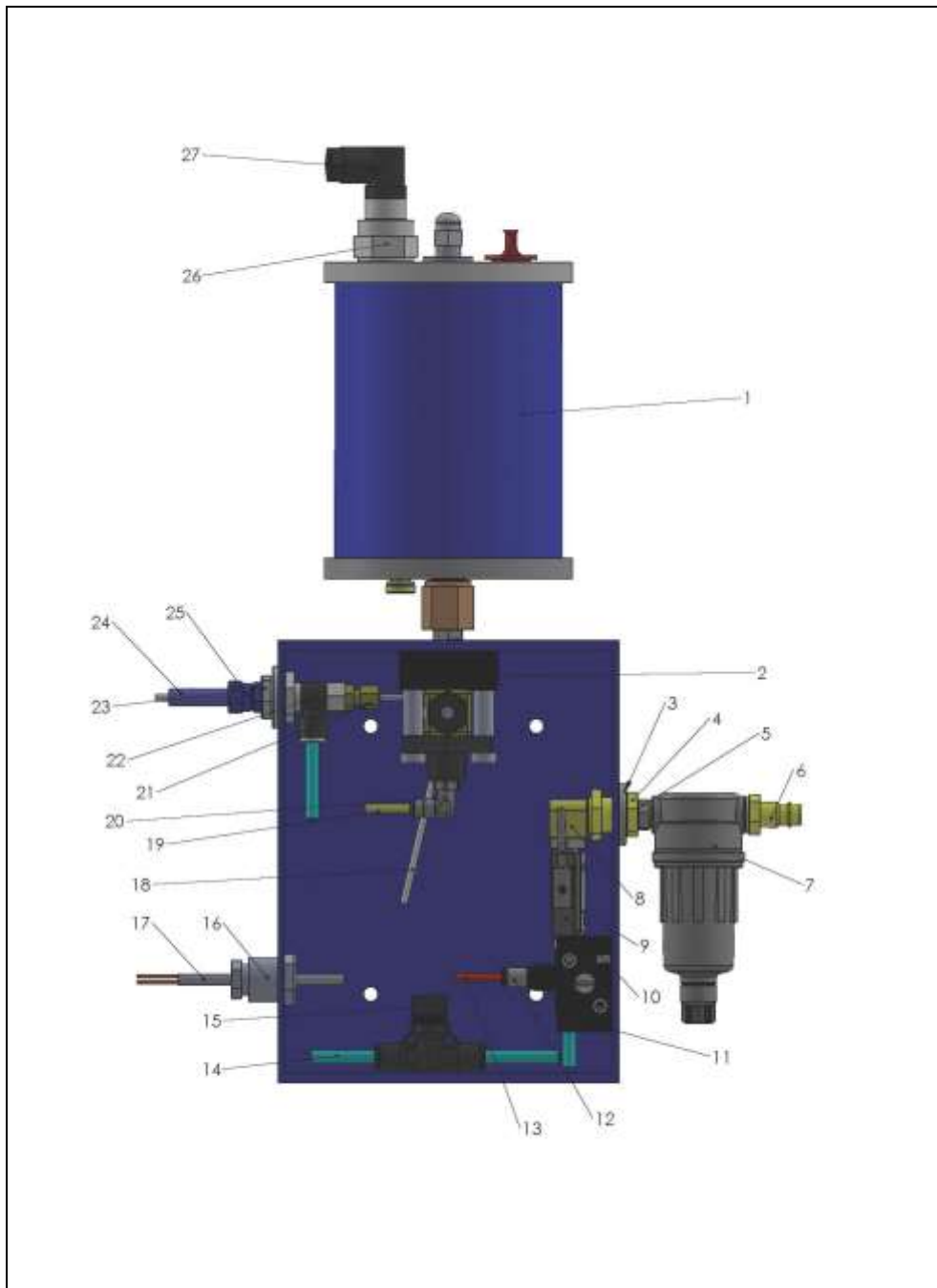

Abb. 17 Wiring scheme for the opener type



Abb. 18 Wiring scheme for the closer type

14 EC Declaration of conformity

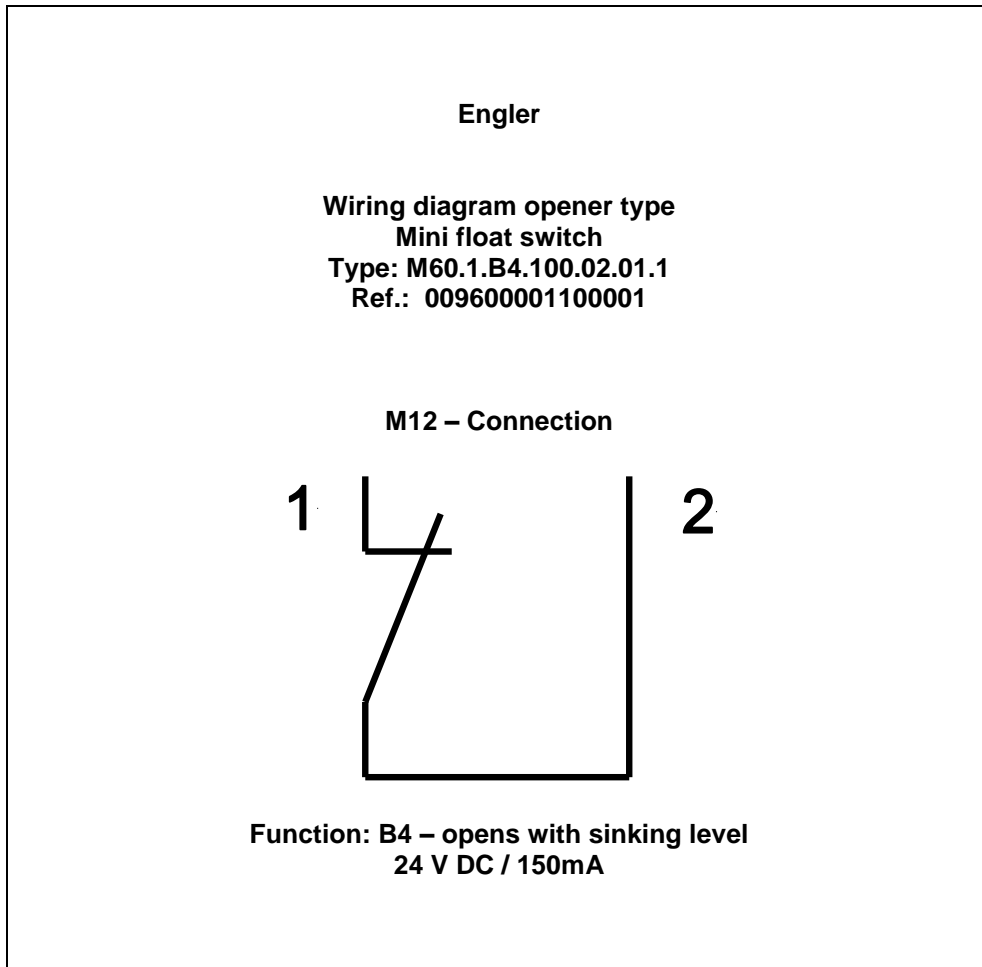

Einbauerklärung
im Sinne der EG-Richtlinie Maschinen 2006/42/EG Anhang II, 1 B

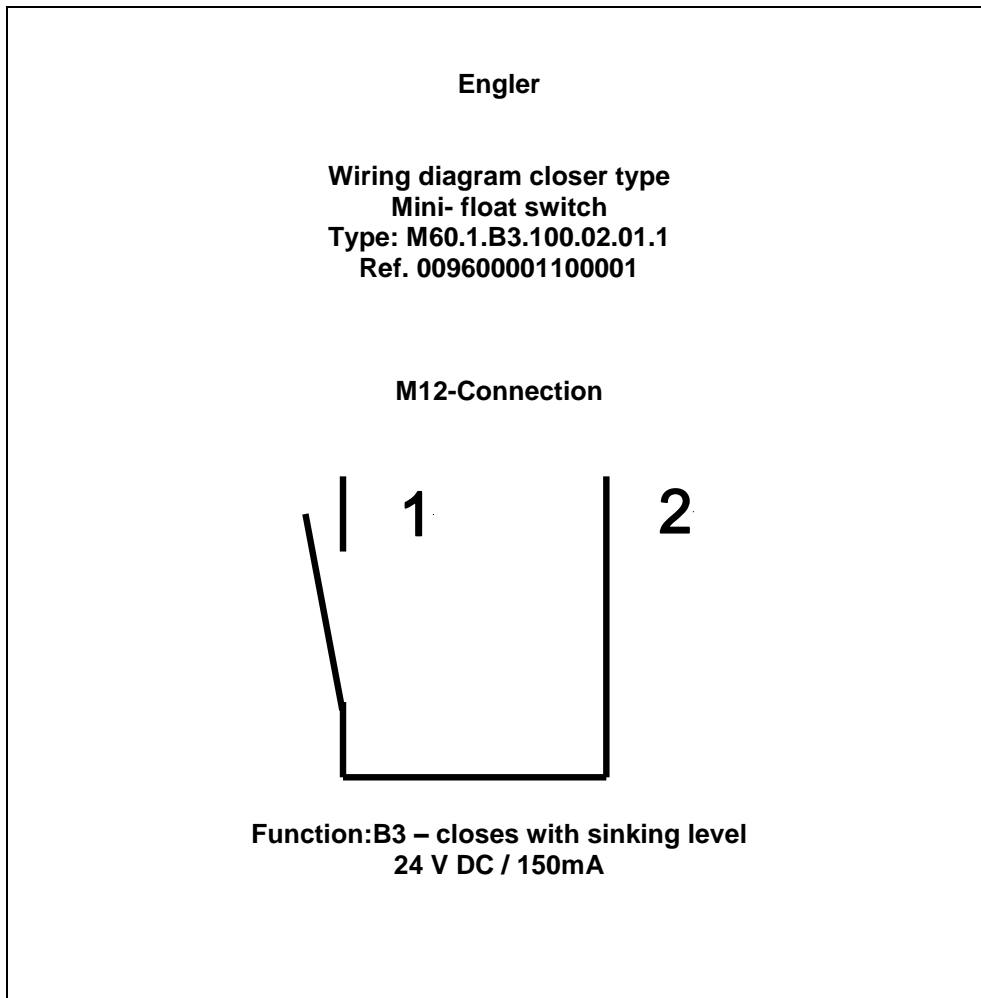
<p>Hersteller</p> <p>Accu-Lube Manufacturing GmbH Glatztasse 29 75433 Maulbronn-Schmie Tel.: (+49) 87043 5612</p>	<p>In der Gemeinschaft ansässige Person, die Bevollmächtigt ist, die relevanten Technischen Unterlagen zusammenzustellen</p> <p>Accu-Lube Manufacturing GmbH Glatztasse 29 75433 Maulbronn-Schmie Tel.: (+49) 87043 5612</p>
--	--

Beschreibung und Identifizierung der unvollständigen Maschine

Produkt/ Erzeugnis	Minimalmengenschmiergerät
Baujahr	2016

Es wird erklärt, dass die folgenden grundlegenden Anforderungen der Maschinenrichtlinie 2006/42/EG erfüllt sind.
1.1.2, 1.1.3, 1.1.6, 1.2.6, 1.3, 1.3.2, 1.3.4, 1.3.9, 1.5.1, 1.5.2, 1.5.3, 1.5.4, 1.5.6, 1.5.8, 1.5.13, 1.5.16, 1.7.2, 1.7.3, 1.7.4

Ferner wird erklärt, dass die speziellen technischen Unterlagen gemäß Anhang VII Teil B erstellt wurden.

Es wird ausdrücklich erklärt, dass die unvollständige Maschine allen einschlägigen Bestimmungen der folgenden weiteren EG-Richtlinien entspricht.

2014/30/EU	Richtlinie 2014/30/EU des Europäischen Parlaments und des Rates vom 26. Februar 2014 zur Harmonisierung der Rechtsvorschriften der Mitgliedstaaten über die elektromagnetische Verträglichkeit (Neufassung)
------------	---

Fundstelle der angewandten harmonisierten Normen entsprechend Artikel 7 Absatz 2

EN ISO 12100:2010-11	Sicherheit von Maschinen-Allgemeine Gestaltungsgrundsätze- Risikobewertung und Risikominderung (ISO 12100:2010)
EN 809:2012-10	Pumpen und Pumpengeräte für Flüssigkeiten – Allgemeine sicherheitstechnische Anforderungen
EN 4414:2011-04	Sicherheit von Maschinen – Sicherheitstechnische Anforderungen an fluidtechnische Anlagen und deren Bauteile – Pneumatik
EN 61000-6-4** 2011-09	Elektromagnetische Verträglichkeit (EMV); Fachgrundnorm Stromausendung, Teil 5-4: Industriebereich
EN 61000-6-2** 2008-03	Elektromagnetische Verträglichkeit (EMV) Teil 6-2: Fachgrundnormen: Störfestigkeit; Industriebereich

Der Hersteller bzw. der Bevollmächtigte verpflichtet sich, einzustellenden Stellen auf begründetes Verlangen die speziellen Unterlagen zu der unvollständigen Maschine zu übermitteln. Die gewerblichen Schutzrechte bleiben hiervon unberührt.

Wichtiger Hinweis! Die unvollständige Maschine darf erst dann in Betrieb genommen werden, wenn gegebenenfalls festgestellt wurde, dass die Maschine, in die die unvollständige Maschine eingebaut werden soll, den Bestimmungen dieser Richtlinie entspricht.

<p>Maulbronn-Schmie, 11.03.2016</p> <p>_____ (Ort, Datum)</p>	 <p>_____ (Herr Jürgen Uhlarz, Geschäftsleitung)</p>
---	--

***) Zutreffend nur bei Ausführung mit Elektromagnetventil oder elektronischem Frequenzgeber.

Abb. 19 EC Declaration of conformity

15 Index

A		L	
Adjusting knob	9,10,21	Lubricant.....	23,26
Adjusting screw.....	20,22,25	M	
Air filter	13,14	Main components	10
Air flow valve	20	P	
Ambient temperature	12	Pneumatic connection	18
C		R	
Capillary hose.....	8,20	Relative air moisture.....	13
D		Reservoir	8,9,10,12,13,14,15,19,23,25
Dimensions.....	11	Residual materials.....	26
Distributors	25	S	
F		Solenoid valve	18
Filling screw	19,23		
Frequency generator	9, 10, 12, 22, 25		