

Sales documentation U-1530



**Confidential
No hand out to third party**

Content

Technical Highlights

- 3 Design
- 4 Basic construction
- 5 U3-1530 3-Axis-Model
- 6 U4-1530 4-Axis-Model
- 7 U5-1530 5-Axis-Model
- 8 122 positions tool magazine
- 9 Fixed table
- 10 Round table supporter
- 11 High-Precision-Table SPINNER „S“

Spindle data

- 12 In-Line spindle
- 13 Motor spindle

Control

- 14 Siemens 840D
- 15 Heidenhain TNC620
- 16 Heidenhain TNC640
- 17 Ergonomics

Options

- 18 Probe systems
- 19 Options
- 20 High pressure cooling

Technical Data

- 21 Technical Data

Dimension

- 22 Floor plan
- 23 Workroom U3-1530
- 24 Workroom U4-1530
- 25 Workroom U5-1530
- 26 Basement plan 32/54 Tools
- 27 Basement plan 122 Tools

- 28 Contact

Design

- Smart and compact machine concept for small footprint
- Flat machine height, useful for workshops with ceiling height
- Save and easy-care cover, completely made of sheet metal
- Completely closed workroom as standard
- Optimal use of available floor space in your production

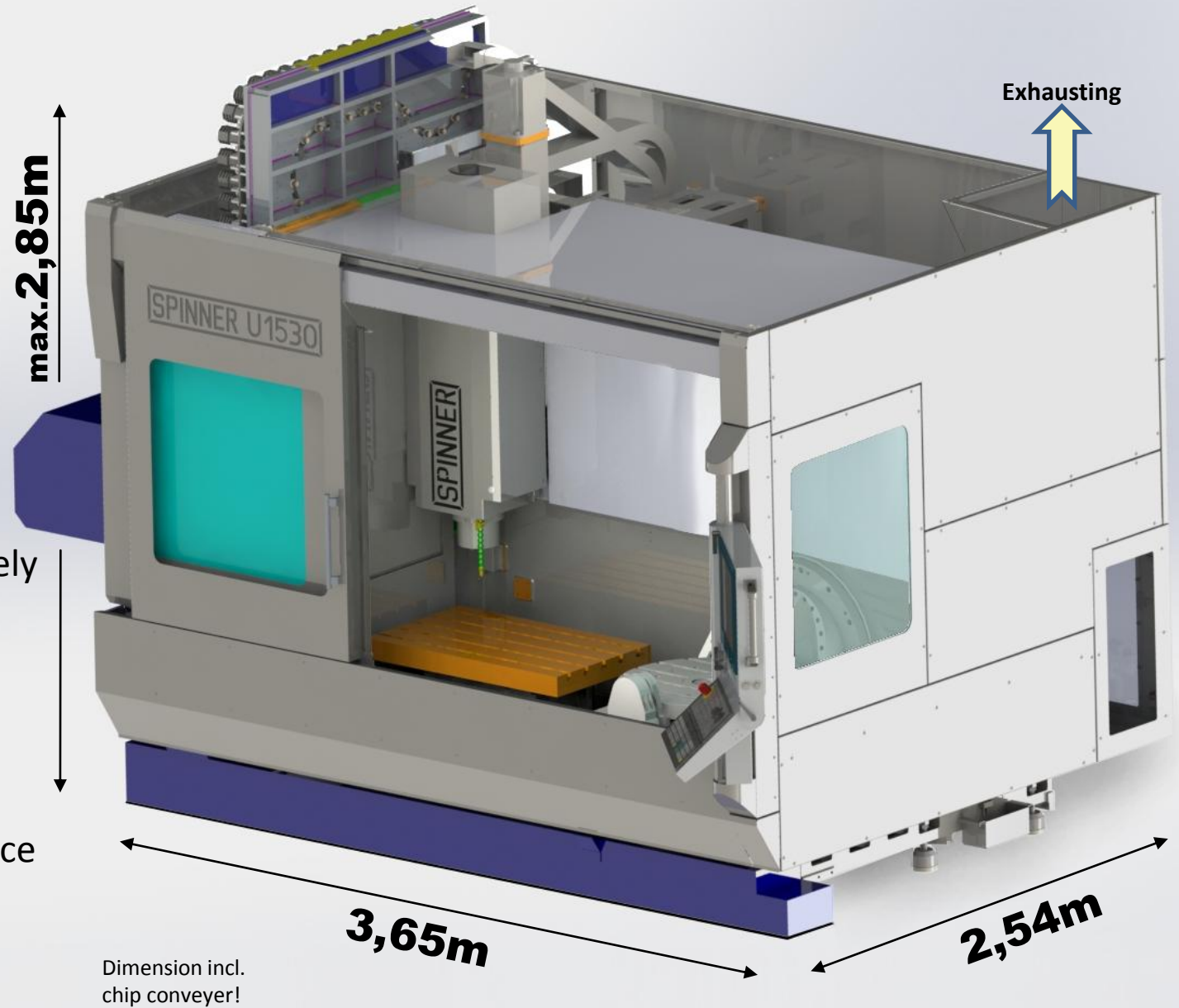

Basic construction

- Heavy FEM-optimized cast with big distances between the guideways
- Moving column design with overhead X-slideway for small lever forces
- Fully integrated tilting table with huge bearings at booth sides
- Direct-drive feed screws without belt drive for precise positioning and large chip volume

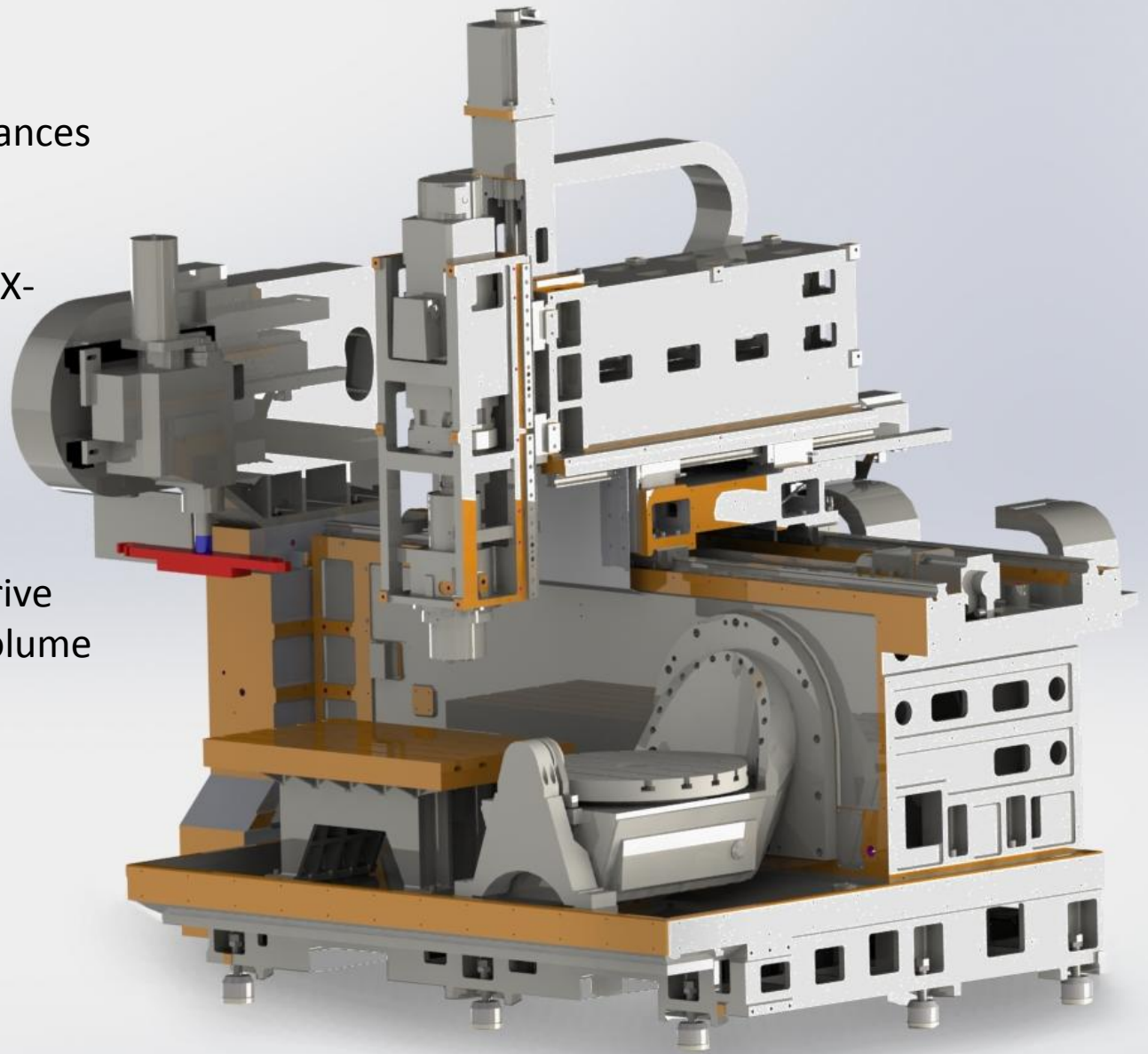

SPINNER U5-1530	
Slide way distance X/Y/Z	609/356/272
Slide way size X/Y/Z	45/45/35
Feed screw size X/Y/Z	40x16
Quantity of linear slide cars X/Y/Z	2x2/2x2/2x2
Manufacturer of slides and feed screws	Rexroth Bosch Group

U3-1530 3-Axis-Model

- Design for classical 3-axis-operations
- High table load, up to 2000Kg
- Table size: 1920mm x 540mm
- Upgrade to 4th axis possible (rotary table)

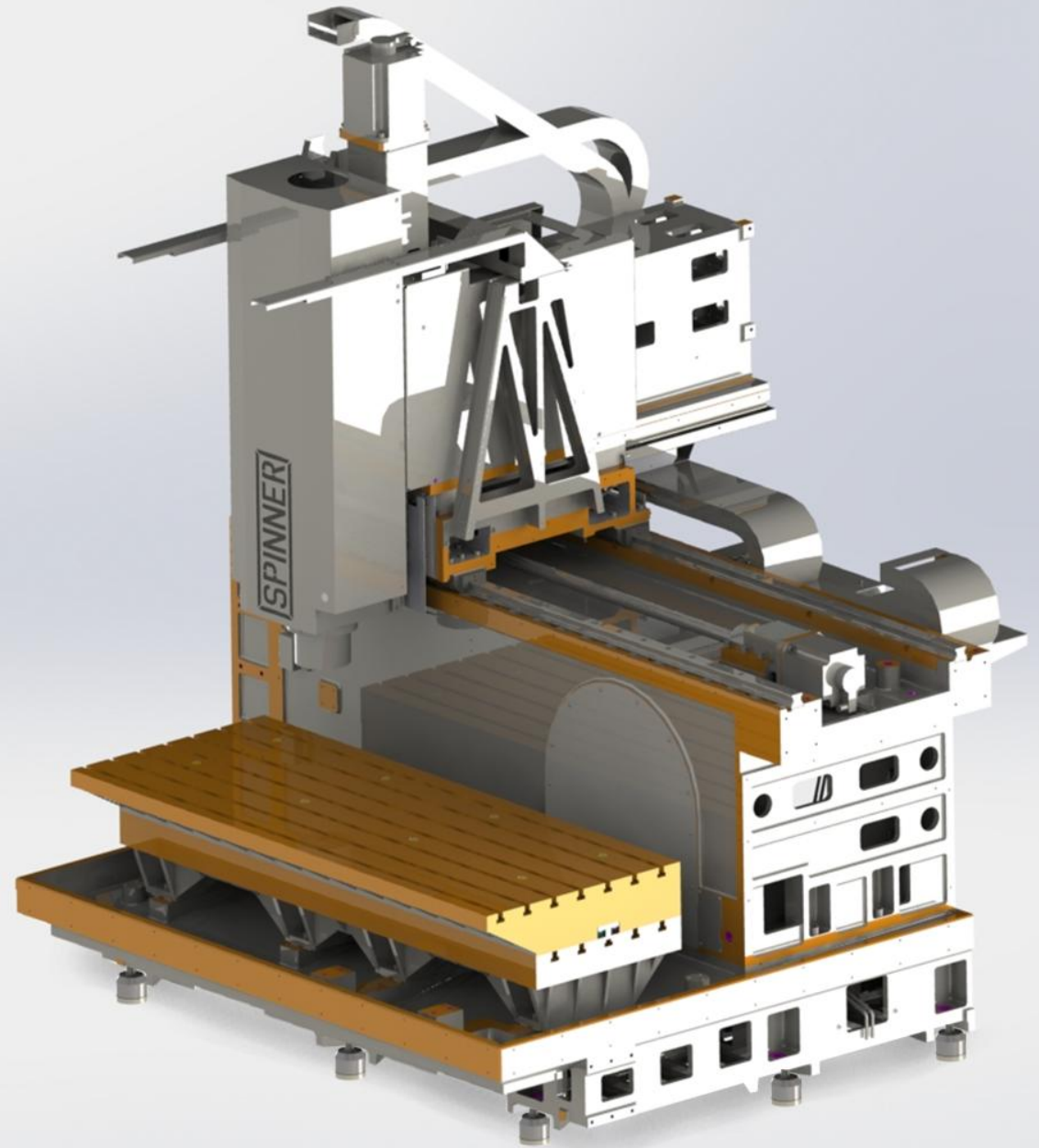
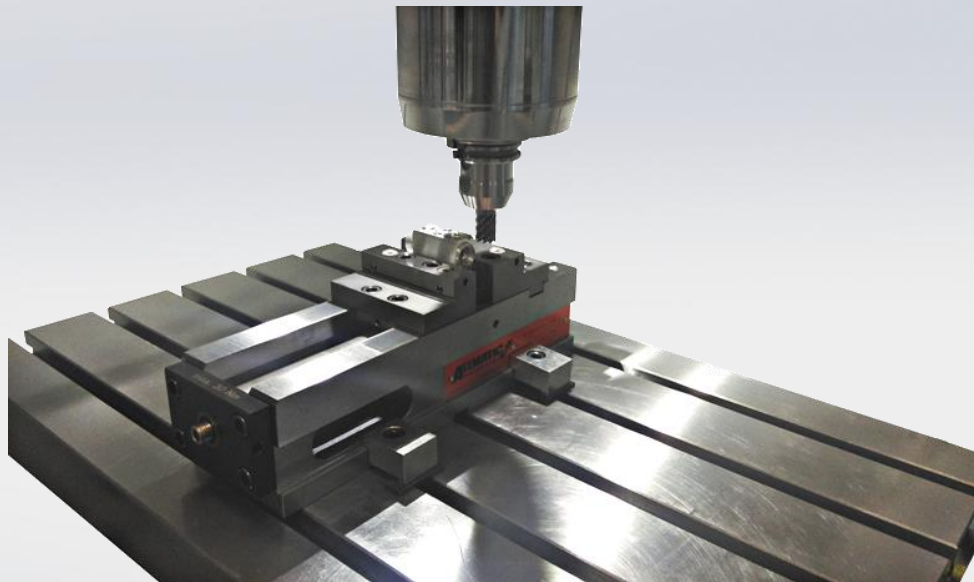

U4-1530 4-Axis-Model

- Machine with one fully integrated rotary CNC-axis
- Hydraulic clamping system*
- Direct measurement system in rotary axis*
- Flat disc for individual clamping devices
- Ideal for installation of multi-side clamping towers, rotary chucks or 2-side tables

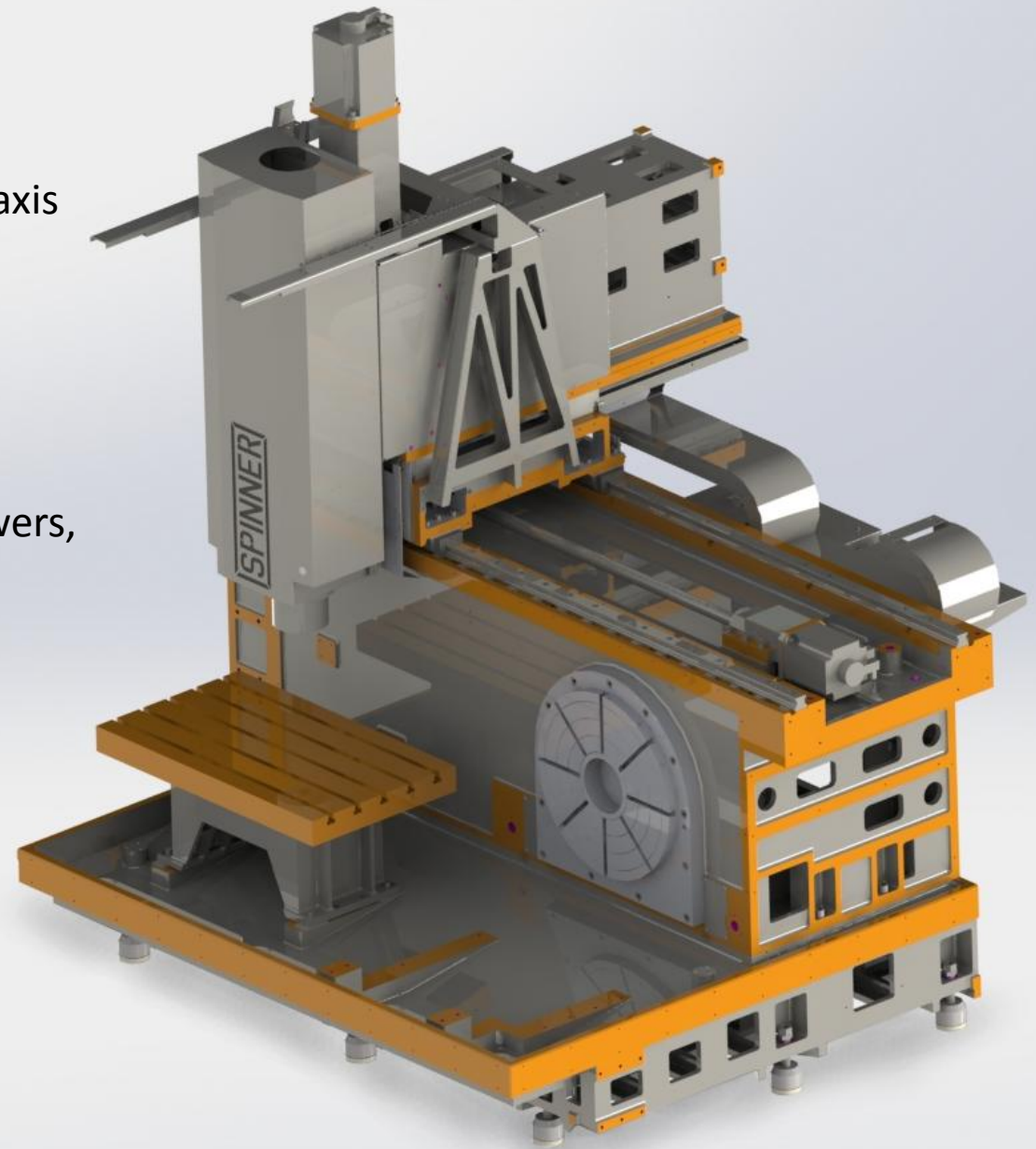
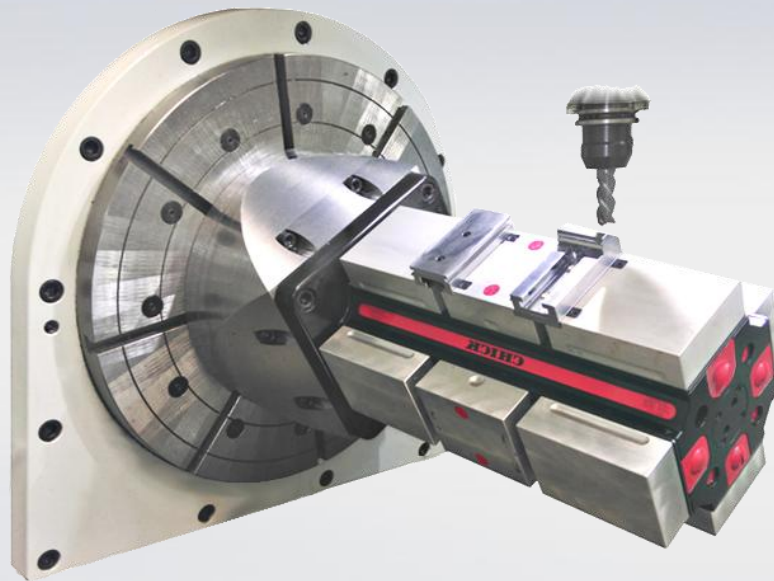

*Option

U5-1530 5-Axis-Model

- 2-axis rotary/tilting-table for 5-axis-machining, not indexed and full interpolated
- Tilting limits: -90° to 110°
- 5-axis-simultaneous movement possible*
- Direct scales in rotary axis*
- Booth axis hydraulic clamped*

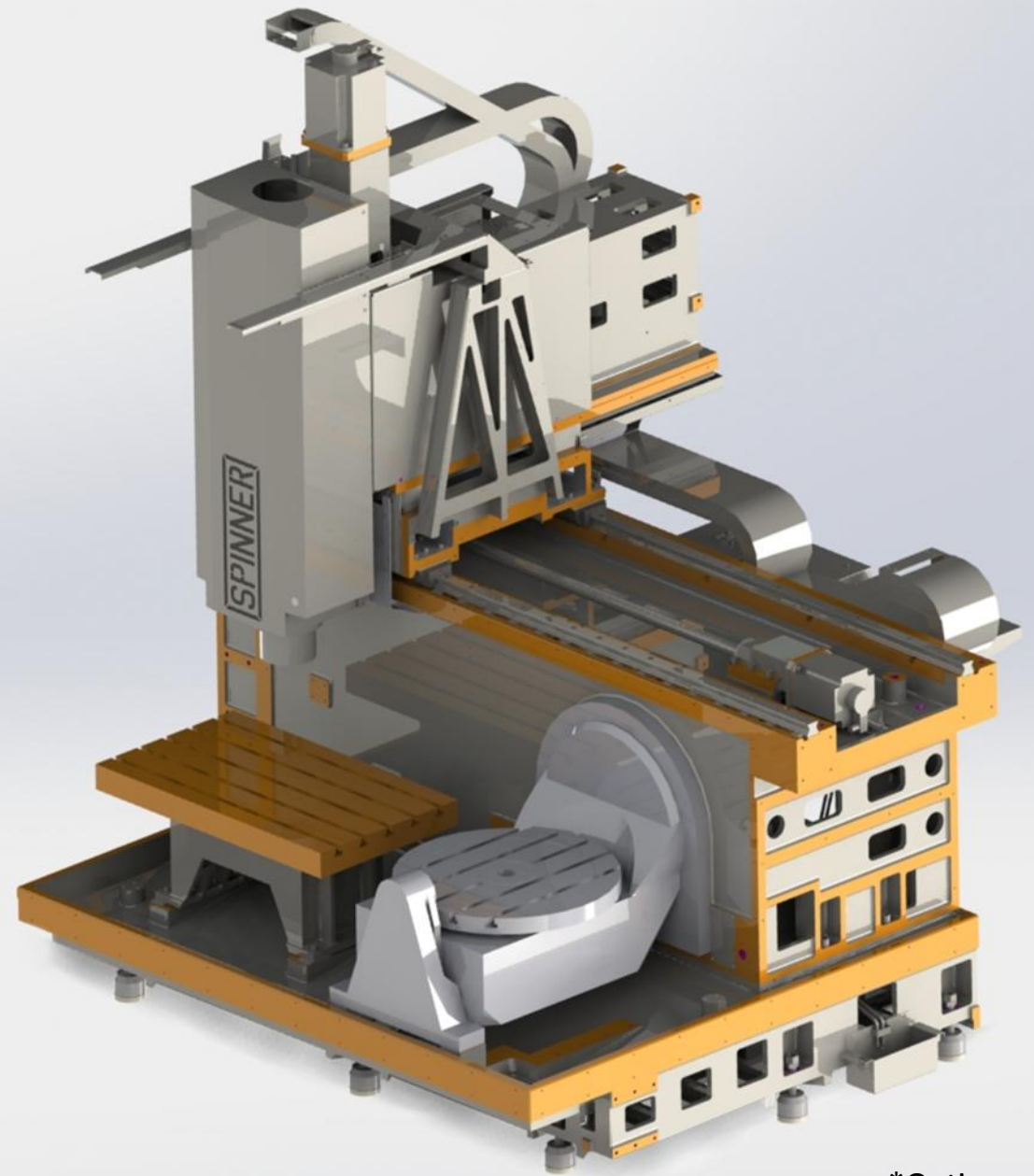
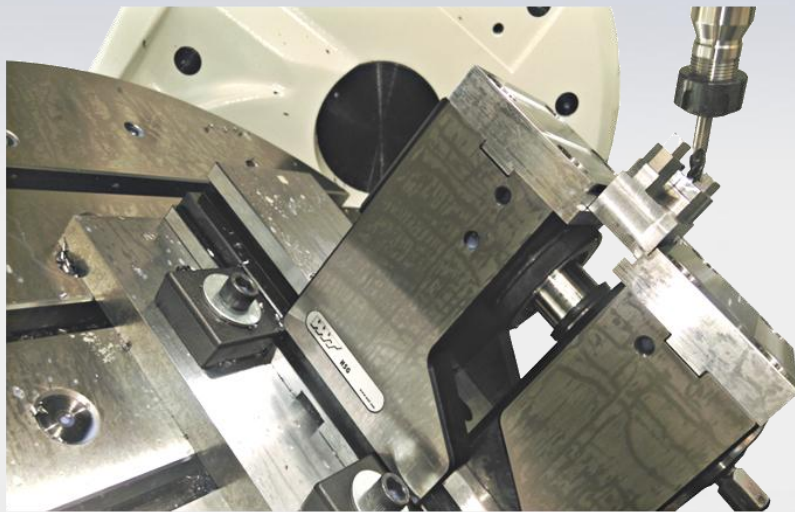

*Option

Option 122-tool-magazine

- With loading door and additional control panel for tool loading
- Very tight design, fully integrated
- Controlled by CNC-motor for high-speed movement and reliable positioning
- Hidden time loading as option
- Art.-Nr. 125685 (SK40)
125686 (HSK63)

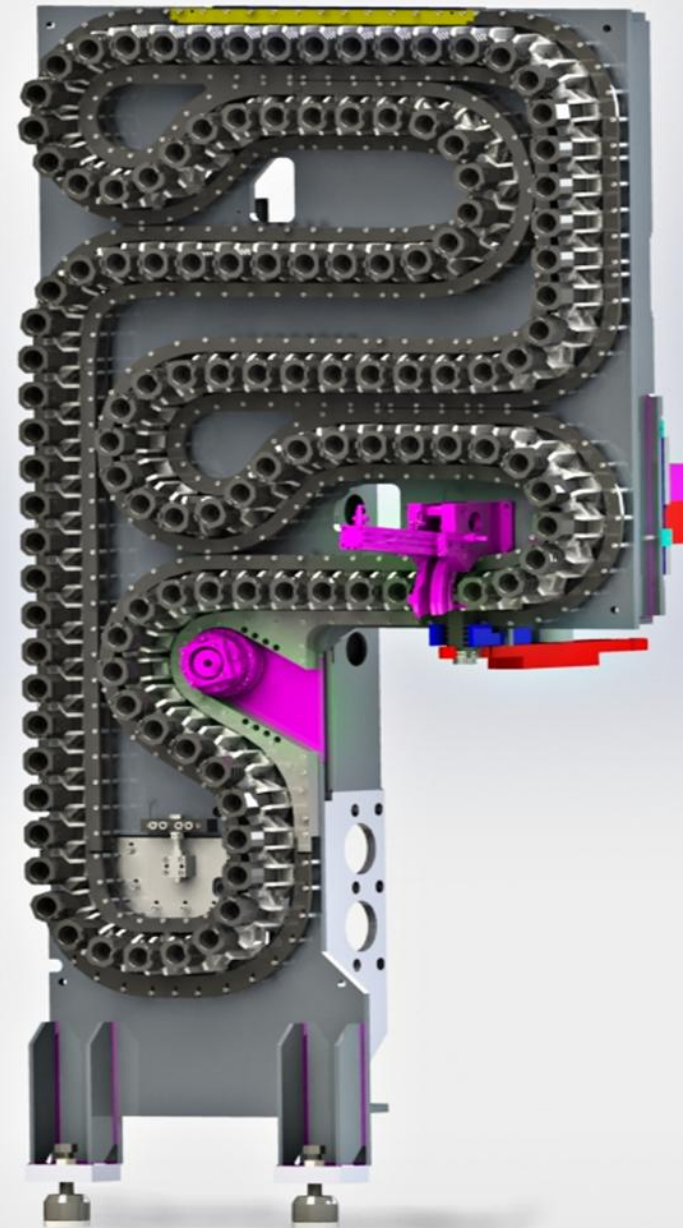

Fixed table

In addition to rotary-/ tilting table

- Unique concept for a maximum of flexibility
- Grinded in same height with tilting table
- Upper part of table removable for machining long work pieces up to $\varnothing 400\text{mm}$ in 4 axis

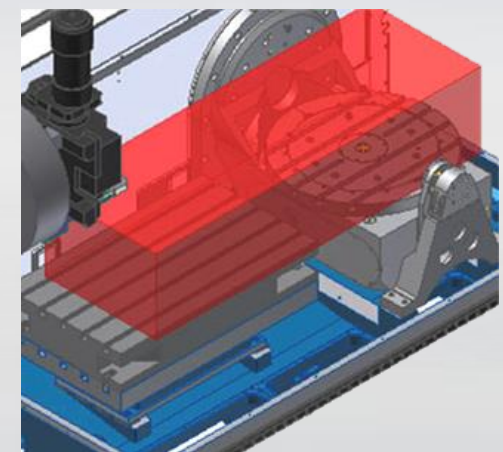
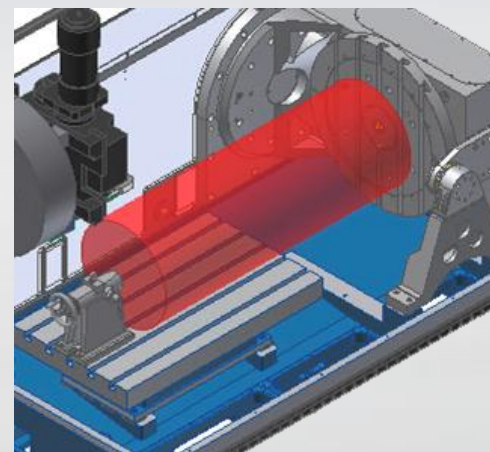
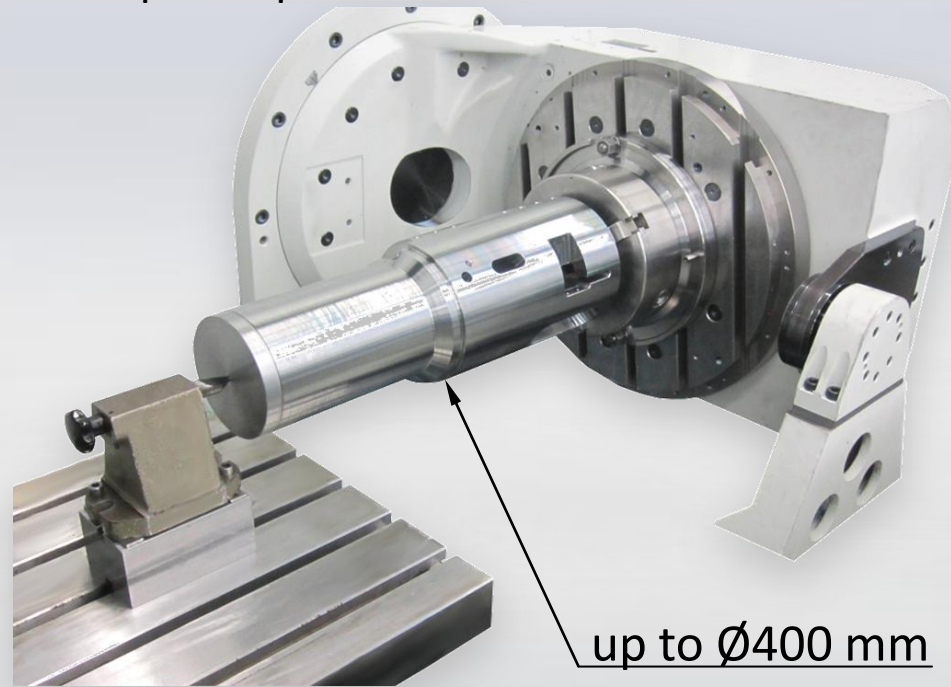

Rotary table supporter

SPINNER U5-1530 with supporter

- Good reinforcement
- Much better damping
- Durable geometry
- Constant conditions
- High table load possible

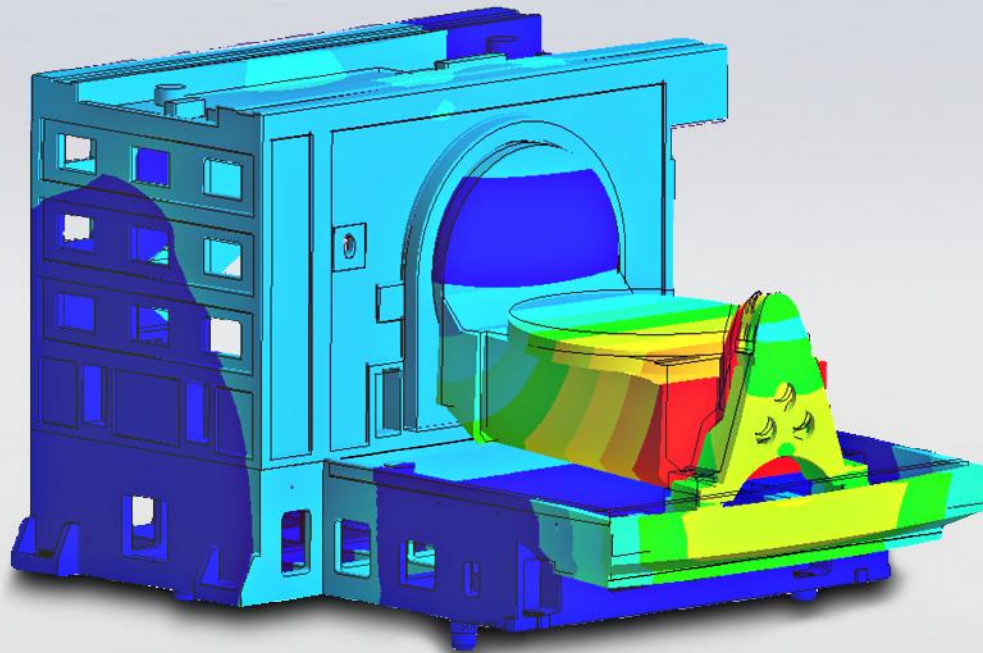

Competitive machine without supporter

- No elimination of lever forces
- Vibrating machine
- Different conditions, depending on working position
- Geometric deviation grows with table load

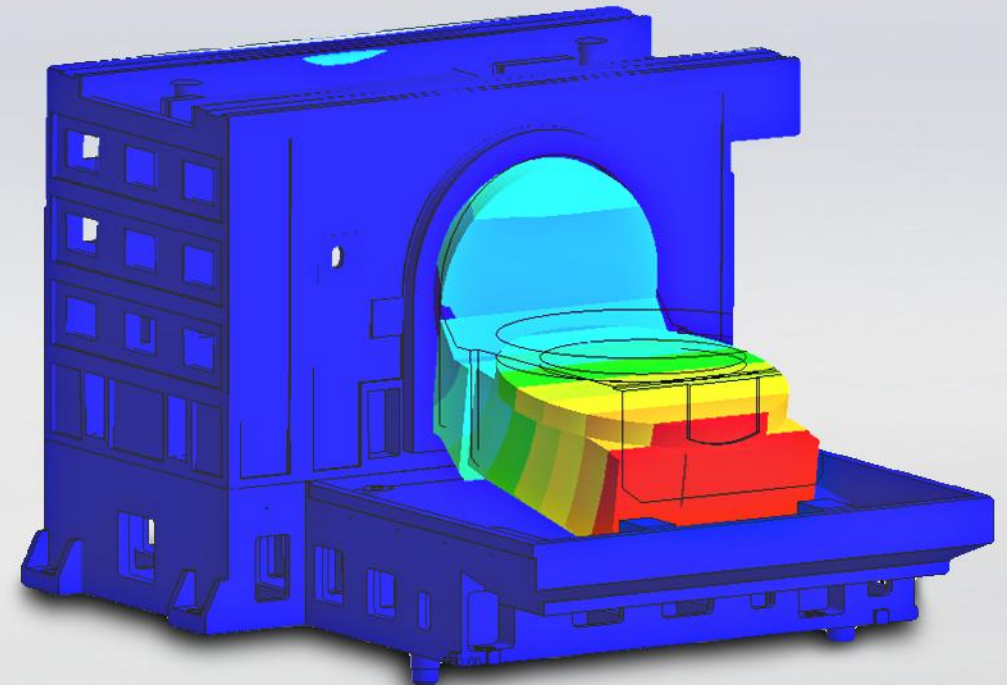

Rotary/tilting-table HIGH-PRECISION VERSION "S"

- More stiff construction because of FEM-optimized cast
- huge bearings at booth sides and direct measure systems in standard
- Strong brakes with
3000Nm at tilting axis B and
1500Nm at rotary axis C

- Large center bore, diameter 106mm
- Rotary feed with 2 or 6 channels and 240bar*
- Counter-Balance: compensates the eccentric mass for:
 - Increased accuracy
 - Less wear of the drive gear
 - Less heating in gearbox
 - High dynamics

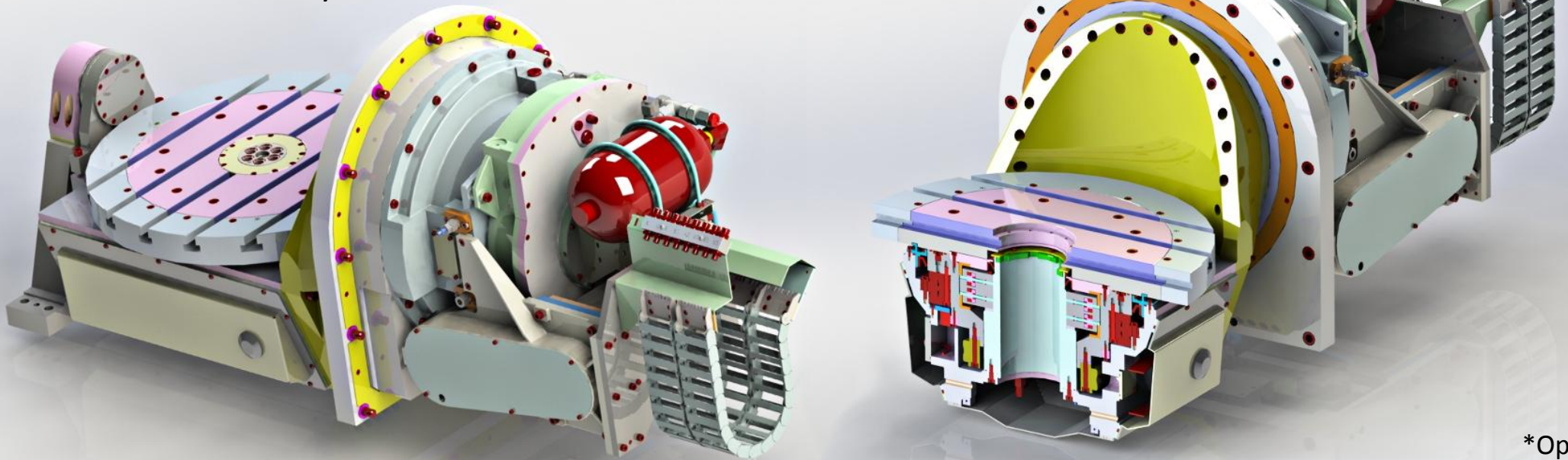

*Option

In-Line direct-drive with up to 15.000rpm

- Cost reduction for maintenance by modular construction, small charge for bearing replacement
- No belt-drive, no noises, no maintenance
- No additional cooling systems are required

Spindle	12000	15000
Max. Rpm	12.000 min ⁻¹	15.000 min ⁻¹
Cone	SK40 (BT40, HSK63)	
Power max.	25 kW	
Torque	135 Nm	

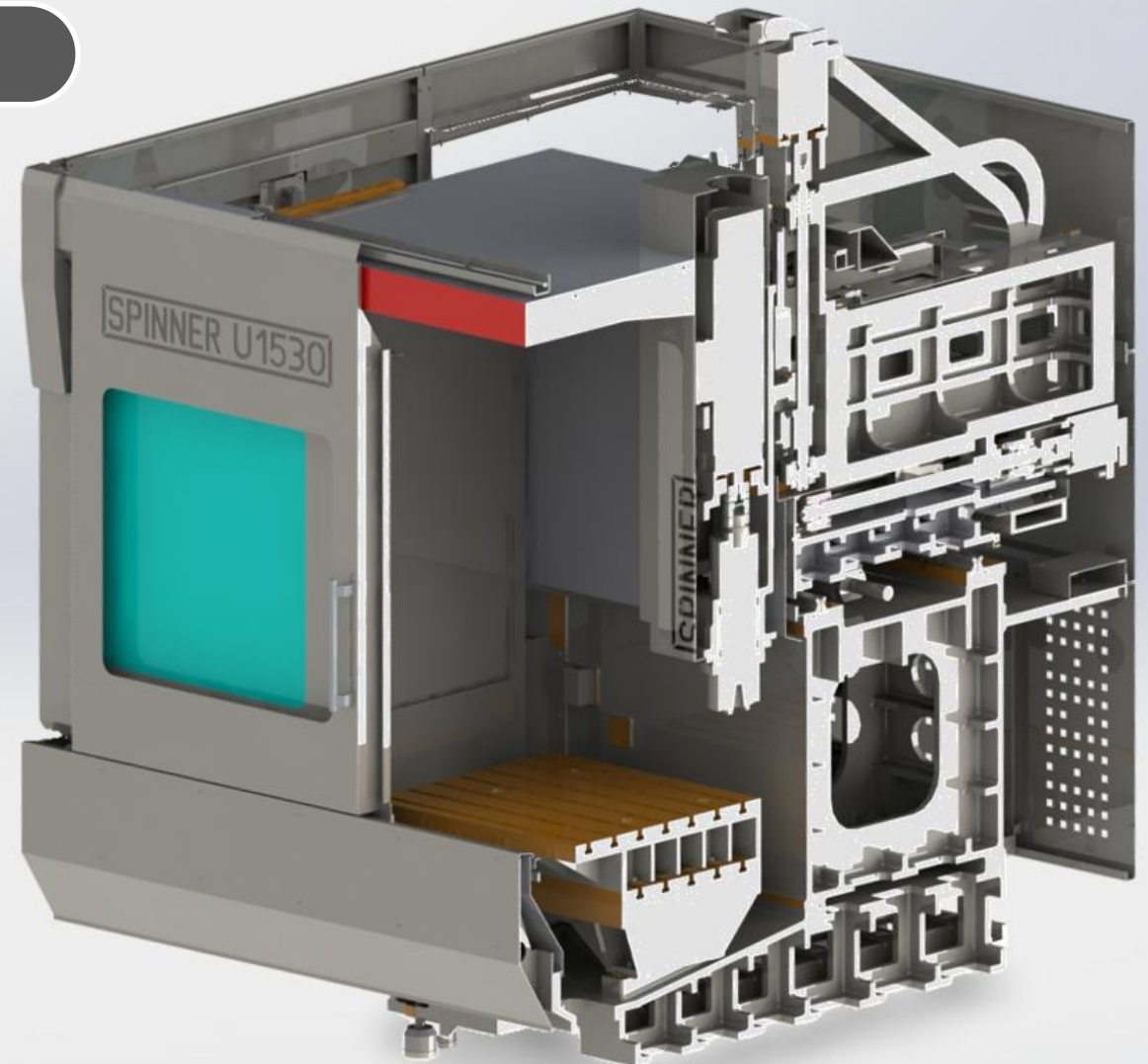

ROYAL

Motor spindles with speed up to 20.000rpm

- Temperature control by water cooling system, minimization of thermally length expansions
- Oil-Air-Lubrication for save spindle operating
- Very High Dynamic
- Overload strength at maximum spindle speed for Mould-Makers

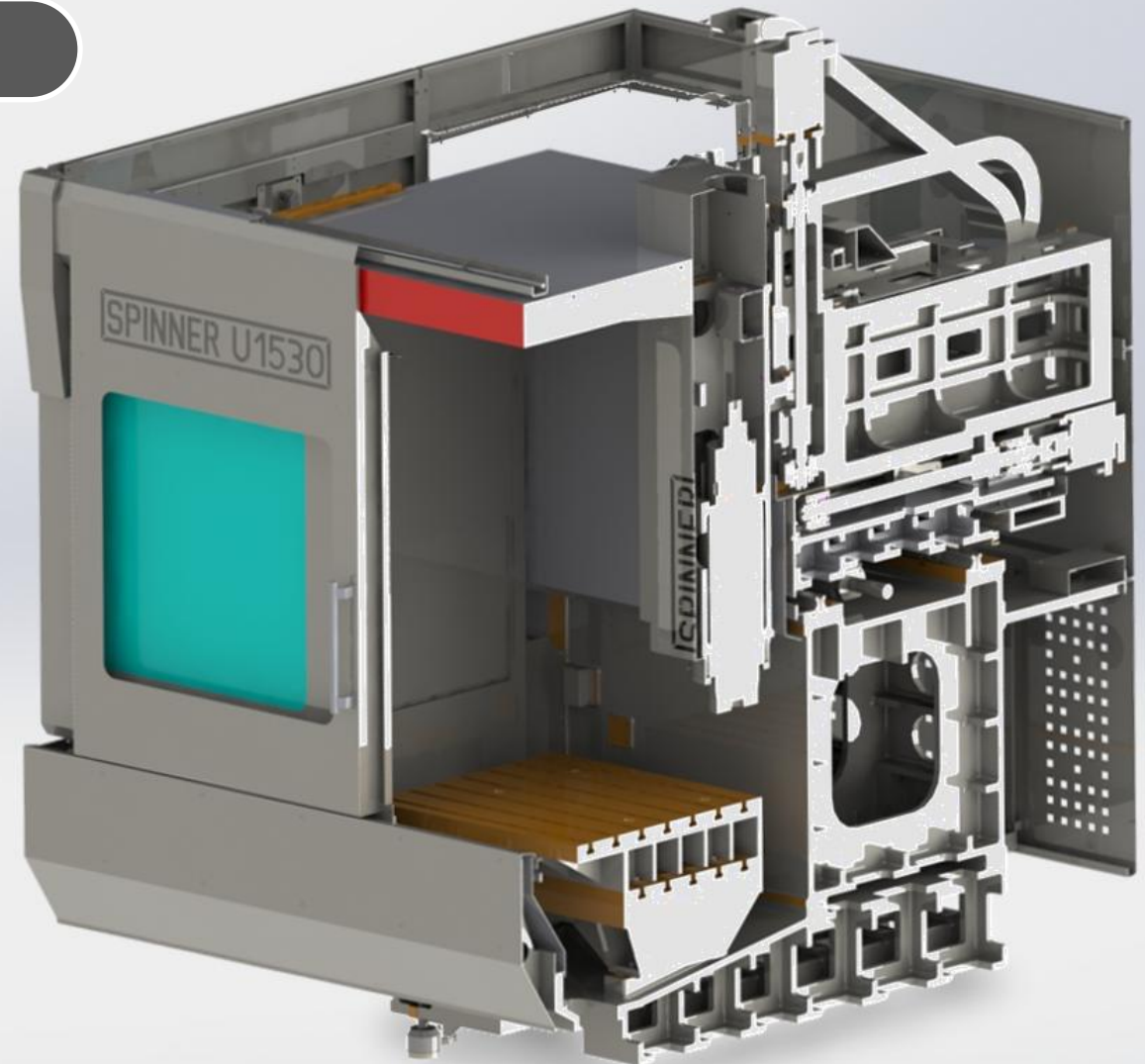

Spindle	20000
Max. Rpm	20.000 min ⁻¹
Cone	HSK63
Power max.	28 kW
Torque	100 Nm

ROYAL

CNC Siemens 840D

- User-Surface OPERATE
- 24"-SPINNER Touch-Panel 4.0
- USB-Interface
- Multi-Functional Operating-Unit with Handwheel and integrated Display available (optional)
- 3 MB User-Memory
- 15 Offsets
- System-cycle-time 125µs
- Positioning-cycle-time 1ms
- Block-cycle-time 3,33ms
- Panel adjustable in height and angle



CNC Heidenhain TNC620

- 15 Inch LCD-Screen
- Full keyboard, Touch-Pad and USB-interface
- Ethernet-Interface
- Spindle-, Feed- and Rapid- Override
- Handwheel integrated on Operator´s-Panel or in additional remote control (Option)
- Compact Flash CFR with 1,8GB User Memory
- Block time 1,5 ms,
controller unit contour interpolation 3,0ms
controller unit fine interpolation 0,2 ms
- Programming in HH-conversational and DIN/ISO
- FK free contour programming and fixed cycles
- NO limit of useable tools
- 3D-Program simulation included



CNC Heidenhain TNC640

- 19 Inch LCD-Touch-Screen
- Full keyboard, Touch-Pad and USB-interface
- Ethernet-Schnittstelle
- Spindle-, Feed- and Rapid- Override

- Handwheel integrated on Operator´s-Panel or in additional remote control (Option)

- SSDR with 21GB User Memory

- Block time 0,5 ms,
controller unit contour interpolation 3,0ms
controller unit fine interpolation 0,2 ms

- Programming in HH-conversational and DIN/ISO
- FK free contour programming and fixed cycles
- NO limit of useable tools
- 3D-Program simulation included



Ergonomics

- Multiple adjustable operating panel
- Small distance from table to operator
- Three huge panorama windows on two sides of workroom for comfortable view on your process
- Big, linear slided and synchronized door for soft movement



Workpiece and Tool Measurement



Touch Probe
TC52
120078

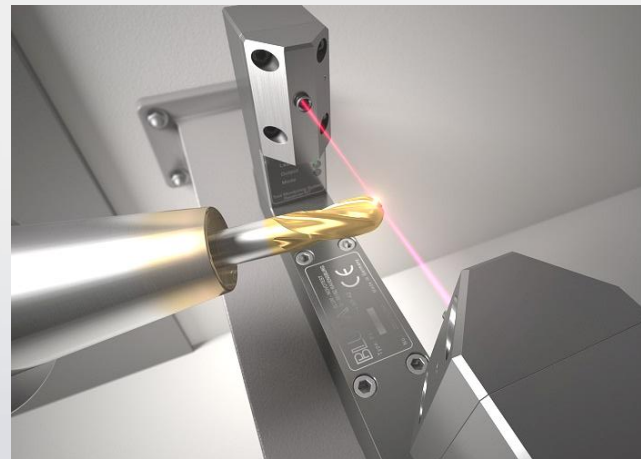

Lasersystem NT Mircro
116030



Evaluation Unit IF59
106545



Mechanical Tool Probe
TC54
106544

Options



Glas scales
Resolution: 0,020 µm
Art.-Nr. 125710 (Siemens)
125711 (Heidenhain)

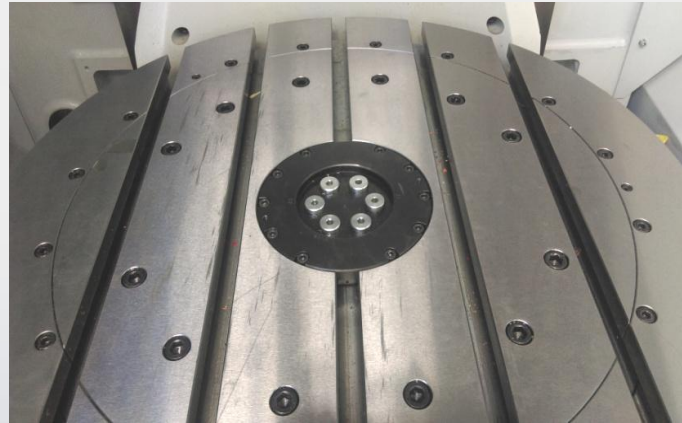

Rotary supply for U5
Art.-Nr. 116033 (2-channel 70bar)
125101 (6-channel 240bar)



Exhausting
Art.-Nr. 111092



Table U4
Double sided
Art.-Nr. 112736



Coolant-Gun
Art.-Nr. 125318

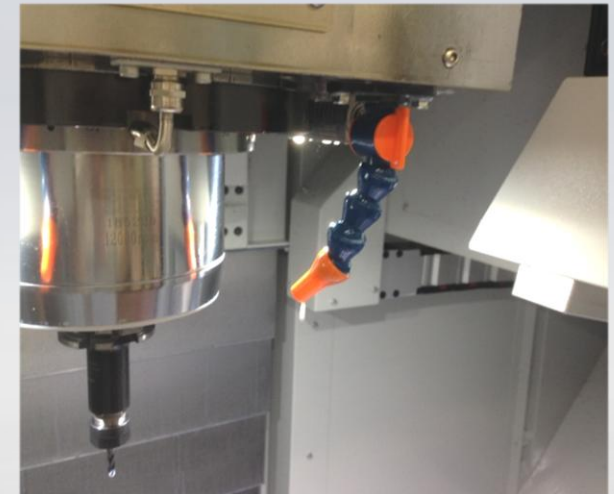

Air nozzle beside spindle
Art.-Nr. 125434
Coolant air through spindle
Art.-Nr. 116036

External coolant tank with Pump 22 / 70bar

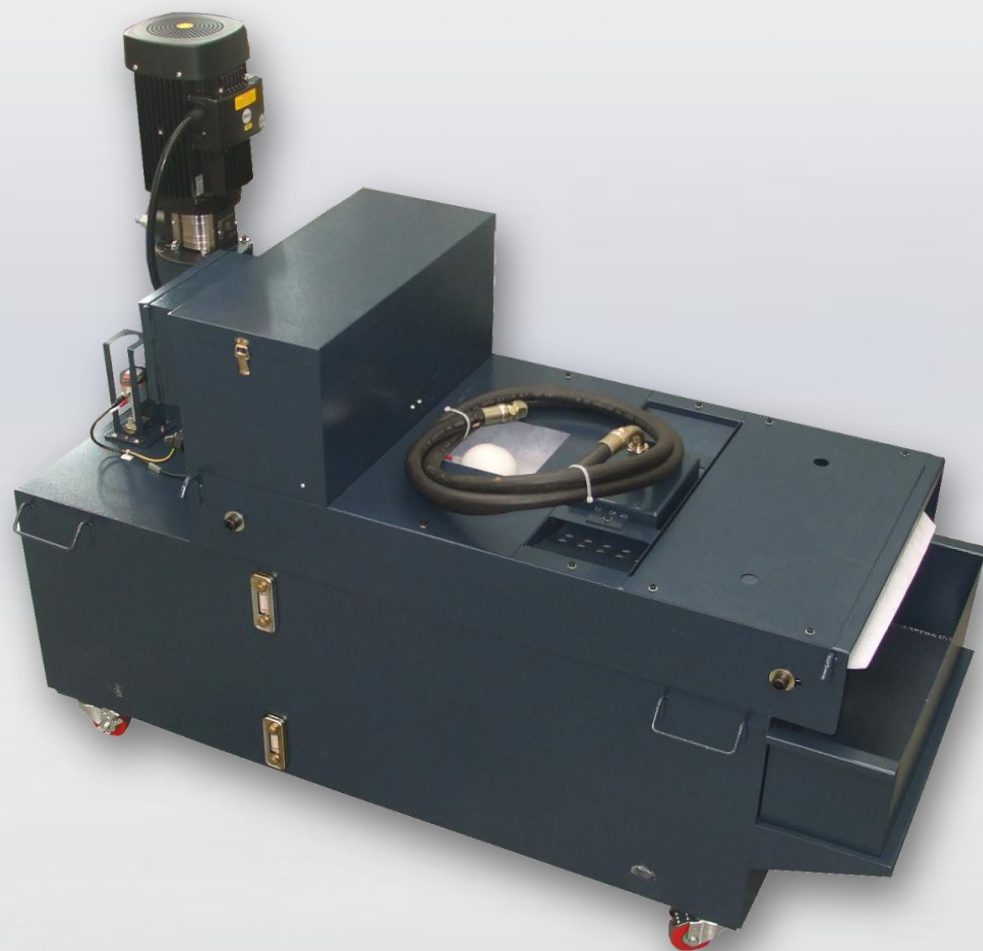

22bar Coolant through Spindle	
Pump	MTR3
Pressure	22 bar
Flow rate	50l/min at 16bar
Filter	Paper line, automatic
Tank Capacity	350 Liter
Part.-Nr. External Tank	116556
Part.-Nr. Preperation CTS	141845

70bar Coolant through Spindle	
Pump	MTS20-80
Pressure	70 bar
Flow rate	20l/min at 60bar
Filter	Paper line, automatic
Tank Capacity	350 Liter
Part.-Nr. External Tank	126071
Part.-Nr. Preperation CTS	141846

Technical data SPINNER U5-1530

Special Highlights:

- **High accuracy because of direct driven feed screws without belt and bearings on booth sides**
- **Less floor space**
- **Very stiff and heavy design**
- **User-friendly, comfortable loading, also by crane**
- **Modular configuration for standard and custom made machines**

Axis	U5-1530 Advanced
Stroke X	1530
Stroke Y	530
Stroke Z	465
Rapid traverse m/min	48
Simultan axis	4 (5*)

Size	
Length (incl. chip conveyer)	3.645
Depth (incl. chip conveyer)	2.420
Height	2798, (2823 at 122 tools)
Req. space (incl. conveyor)	8,821m ²
Weight	8.500

Table	
Diameter	650mm, without ring 500mm
Max. load	500Kg

Spindle	
In-Line spindle	12.000min ⁻¹
In-Line spindle	15.000min ⁻¹
Motorspindle	20.000min ⁻¹

Tool magazin	
Number of tools	32, 54, 122
Max. diameter	76mm
Max. diameter with locked next positions	130mm
Max. length	300mm
Max. weight	7Kg

Control	
	Operate 4.5 Siemens840Dsl 15"
	Heidenhain TNC620/640* 15"/19"

*)Option

Layout

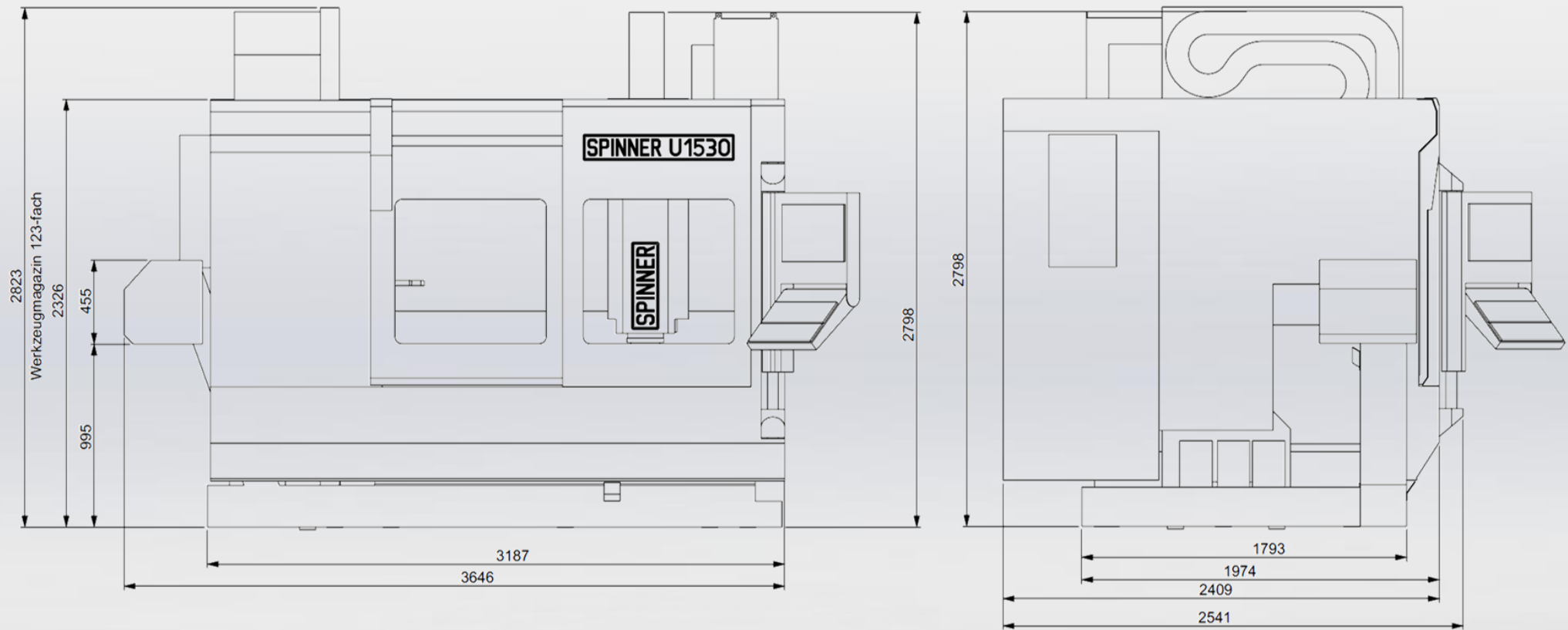

Minimum doorway for transport on steel rollers
 32/54 tools:
 Door width: 2,58 meter
 Door height : 2,8 meter

Minimum doorway for transport on steel rollers
 122 tools:
 Door width: 2,58 meter
 Door height : 2,86 meter

Work room
U3-1530

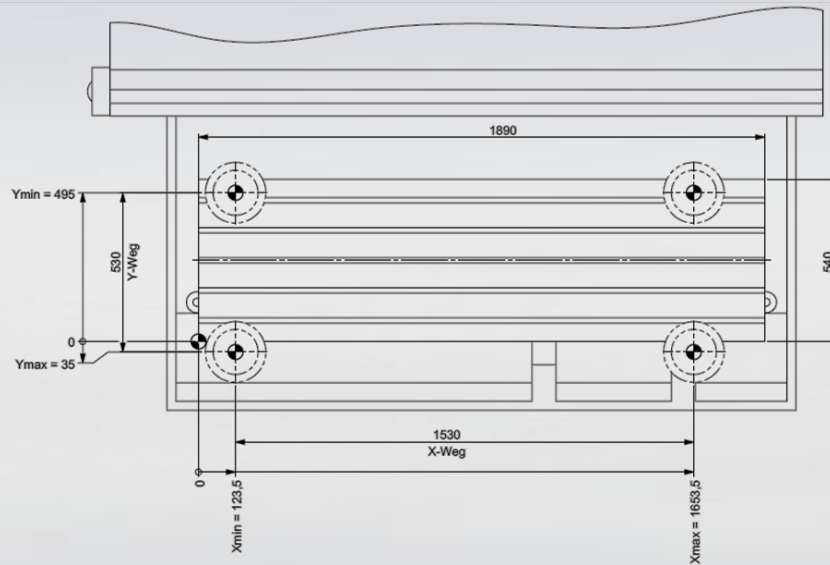
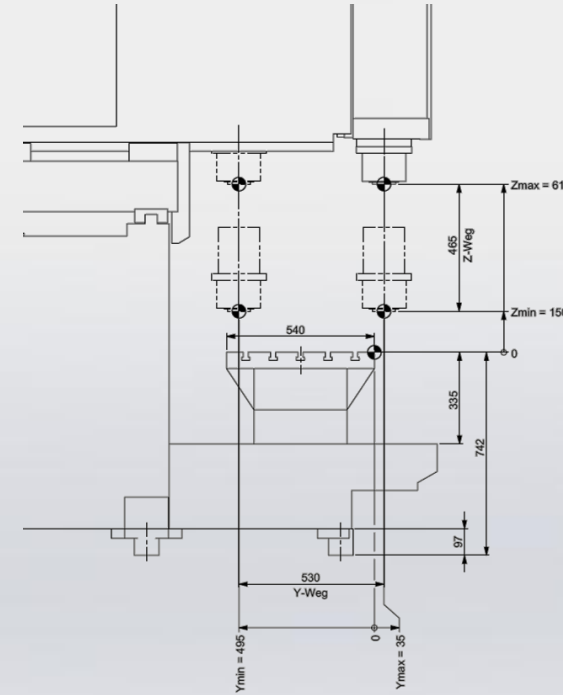
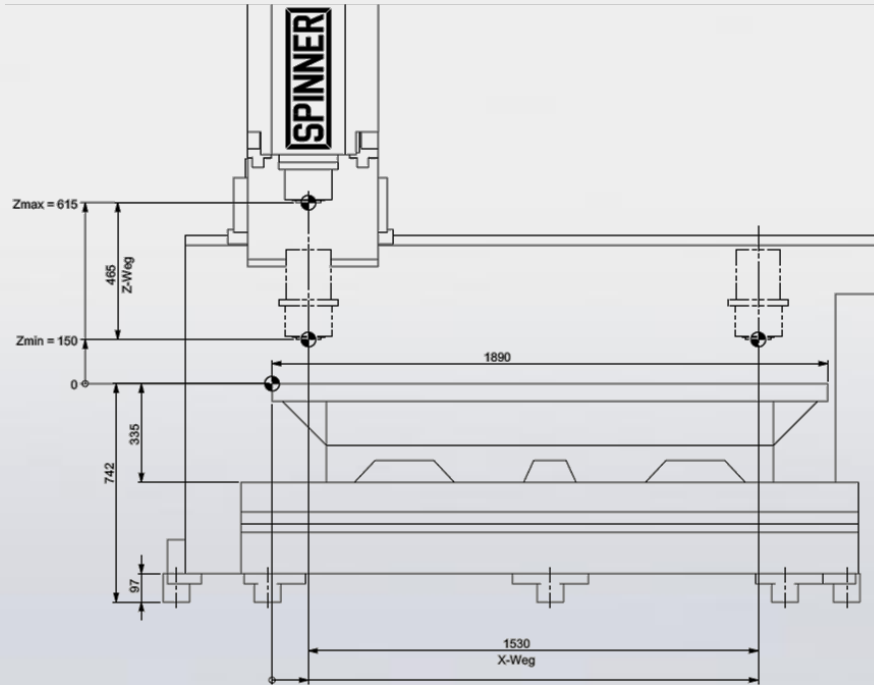

Work room
U4-1530

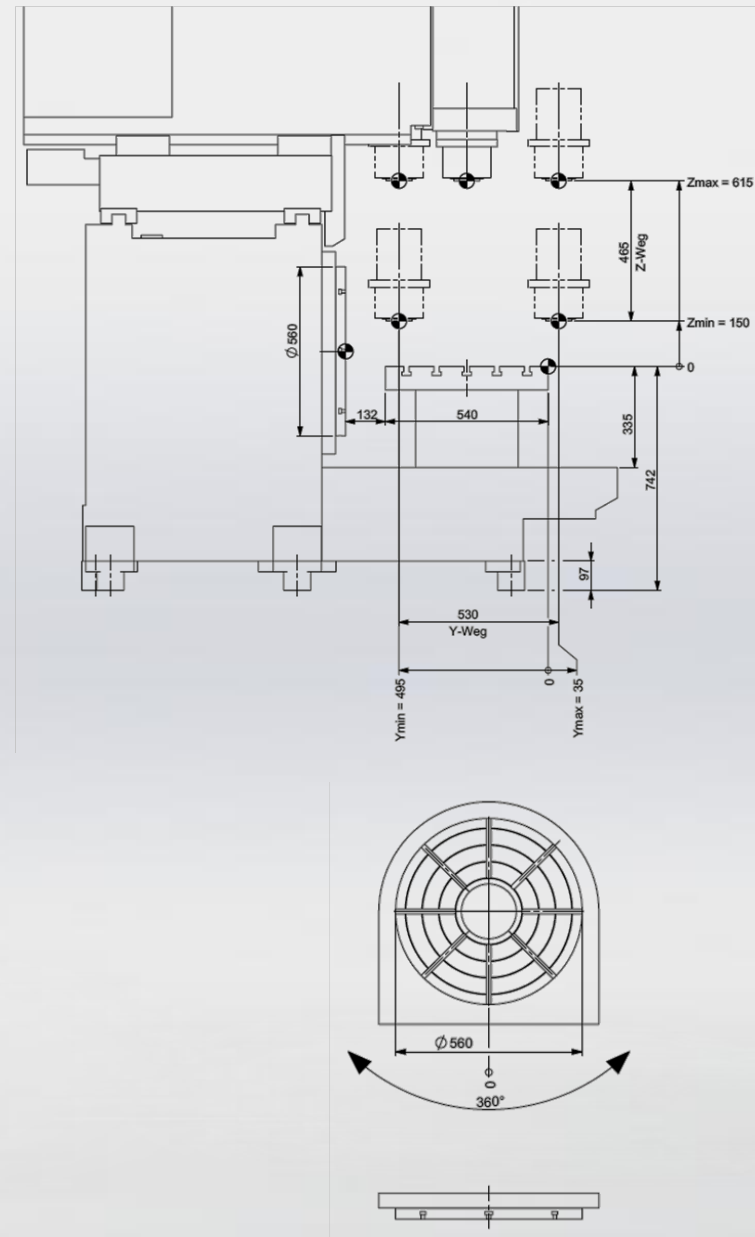
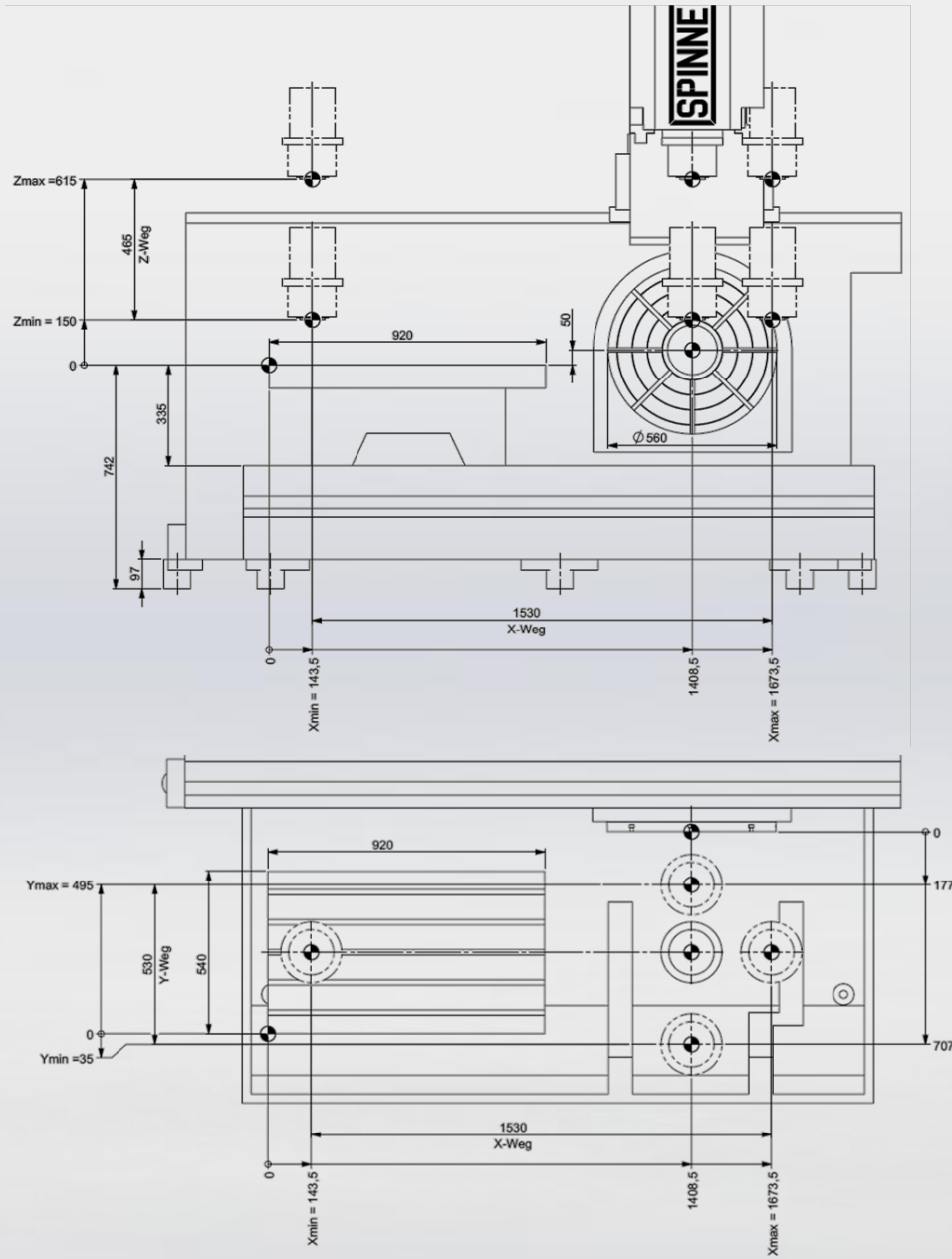

Work room
U5-1530

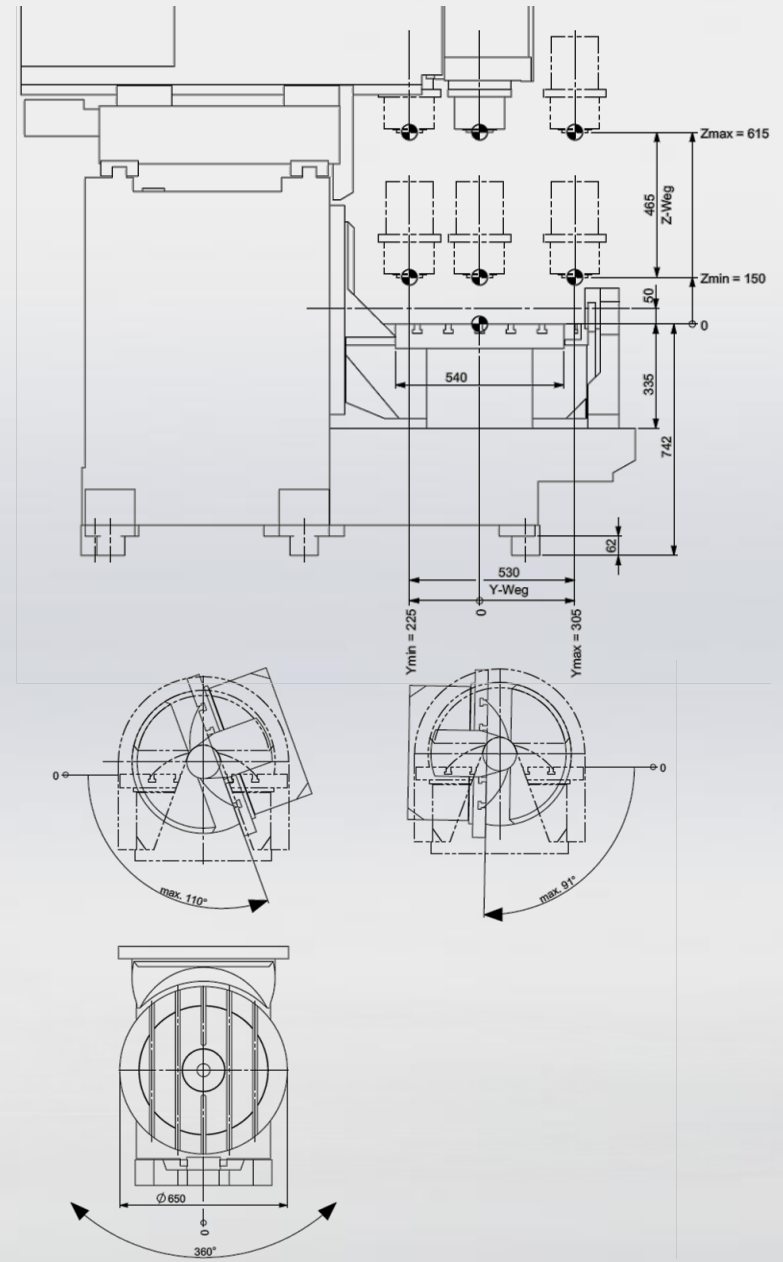
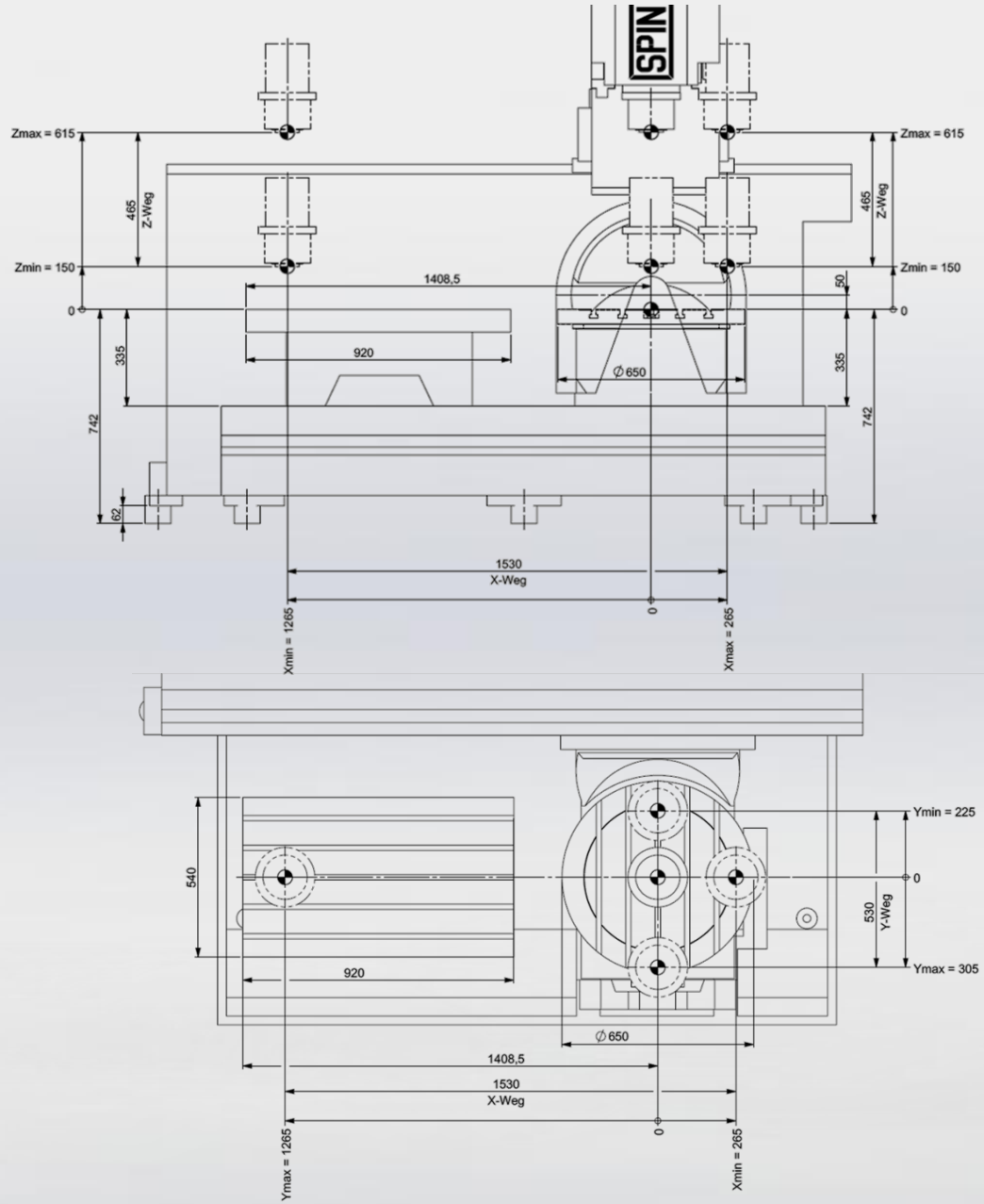

Basement plan
32 / 54 tools

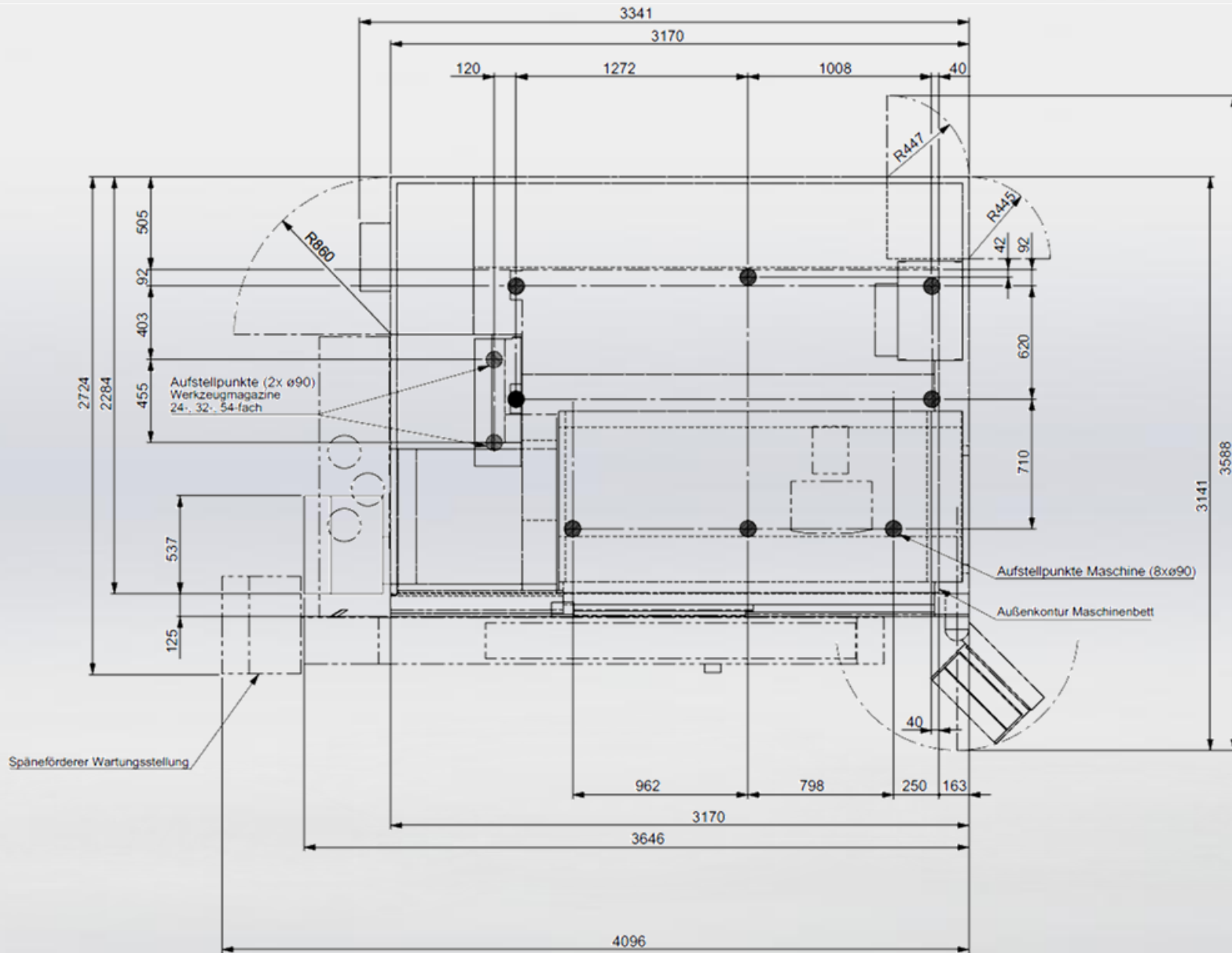

Basement plan
122 tools

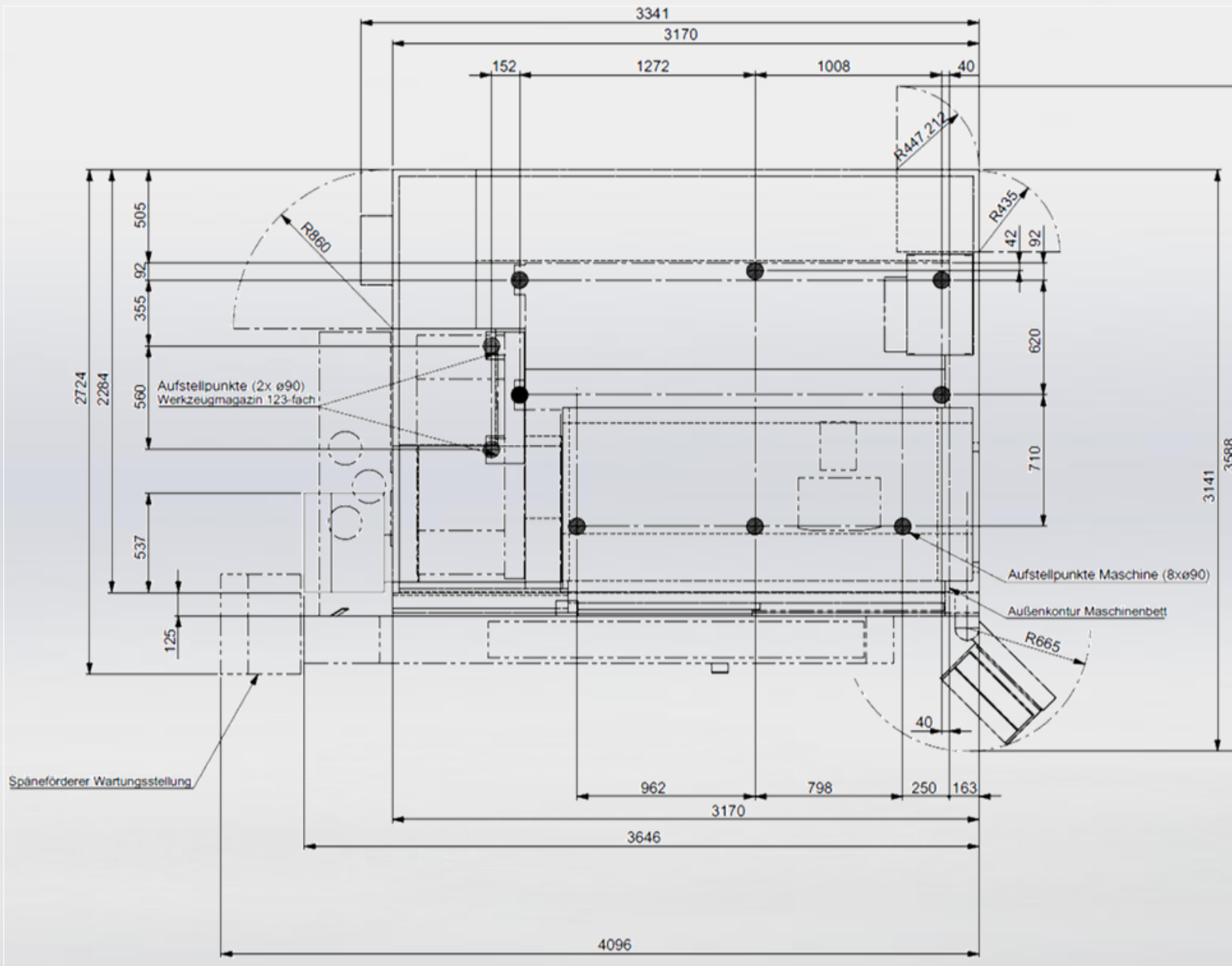



SPINNER Machine Tools GmbH

Rudolf-Diesel-Ring 24

D-82054 Sauerlach

Tel: 08104 / 803-0

Fax: 08104 / 803-19

sales@spinner.eu.com

www.spinner.eu.com