

SPINNER

TC610L

Precise Universal Lathe



Mechanical Engineering
Made in Europe

www.spinner.eu.com
sales@spinner.eu.com

Machine Highlights



Stable
Compact
Dynamic
Universal
Precise

Powerful tool drive
in the turret

Rigid SPINNER servo turret
with BMT45 toolholder

CNC-steady rest

Real Y-axis

Rigid machine
base as a one-
piece casting

CNC-tailstock

Modern
motorspindles with
65 mm or 85 mm
bores

With modern linear
guides on rigid
cast construction

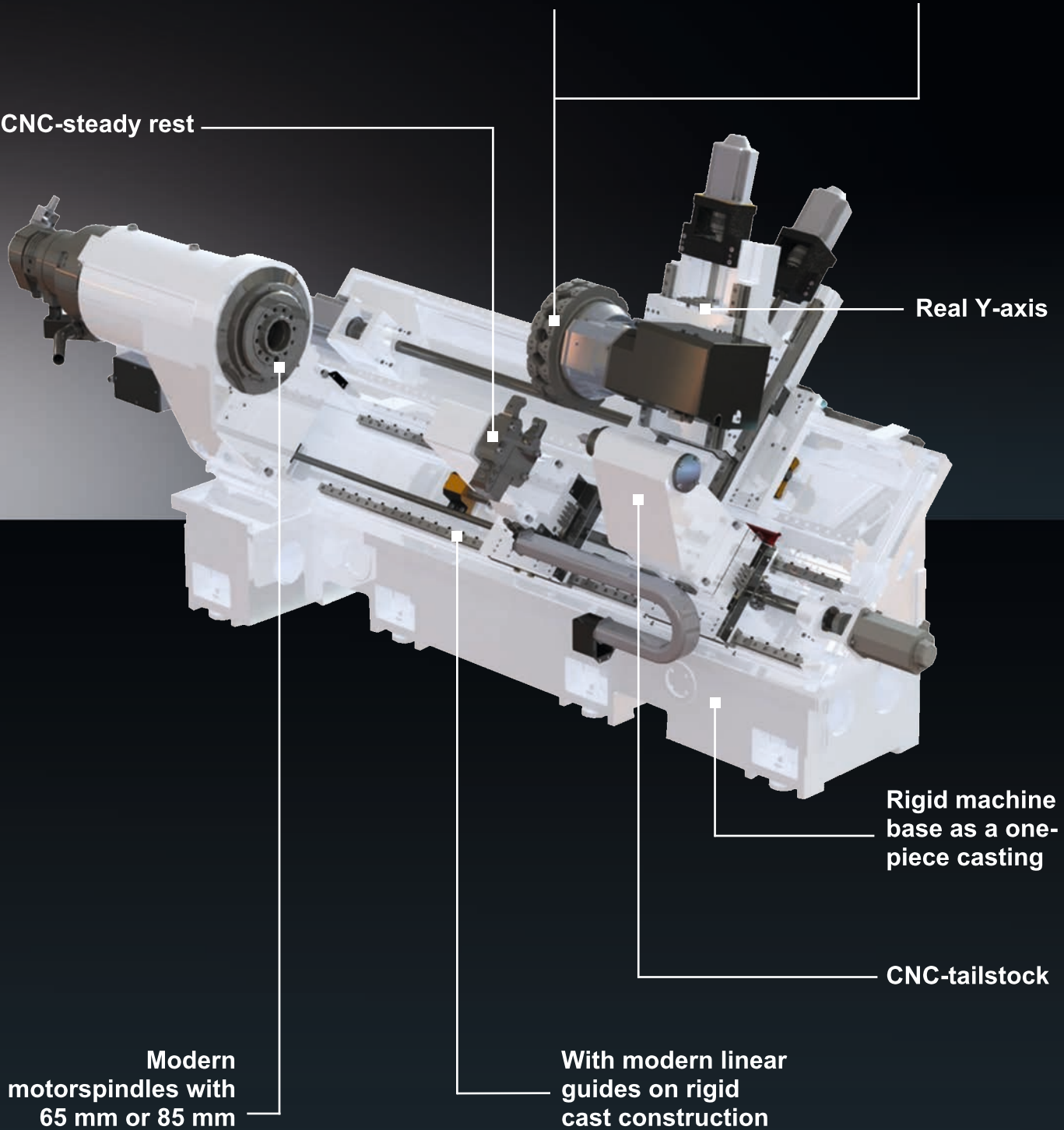

- Rigid SPINNER-turret with high milling performance
- 16 tool stations BMT45

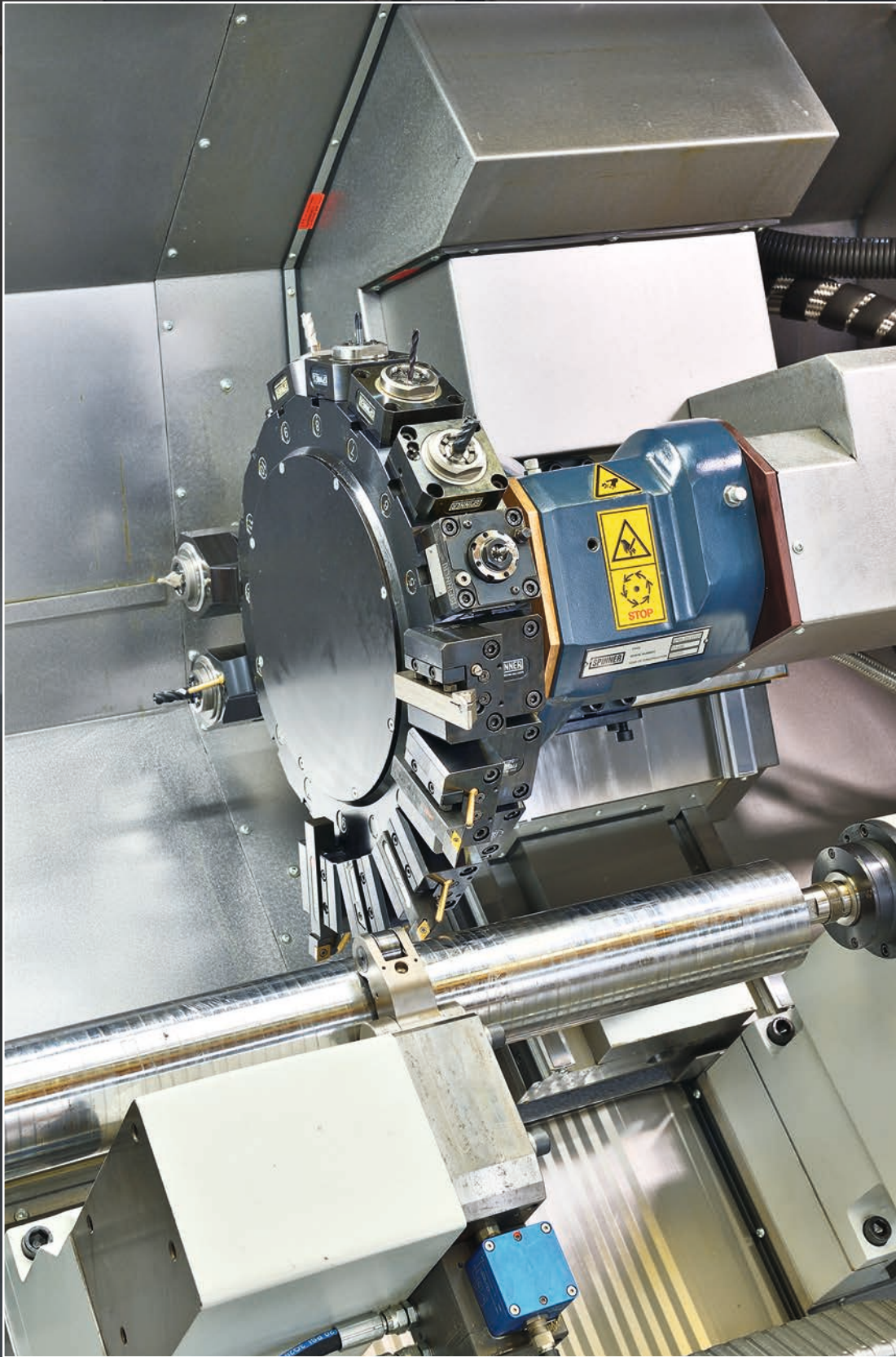
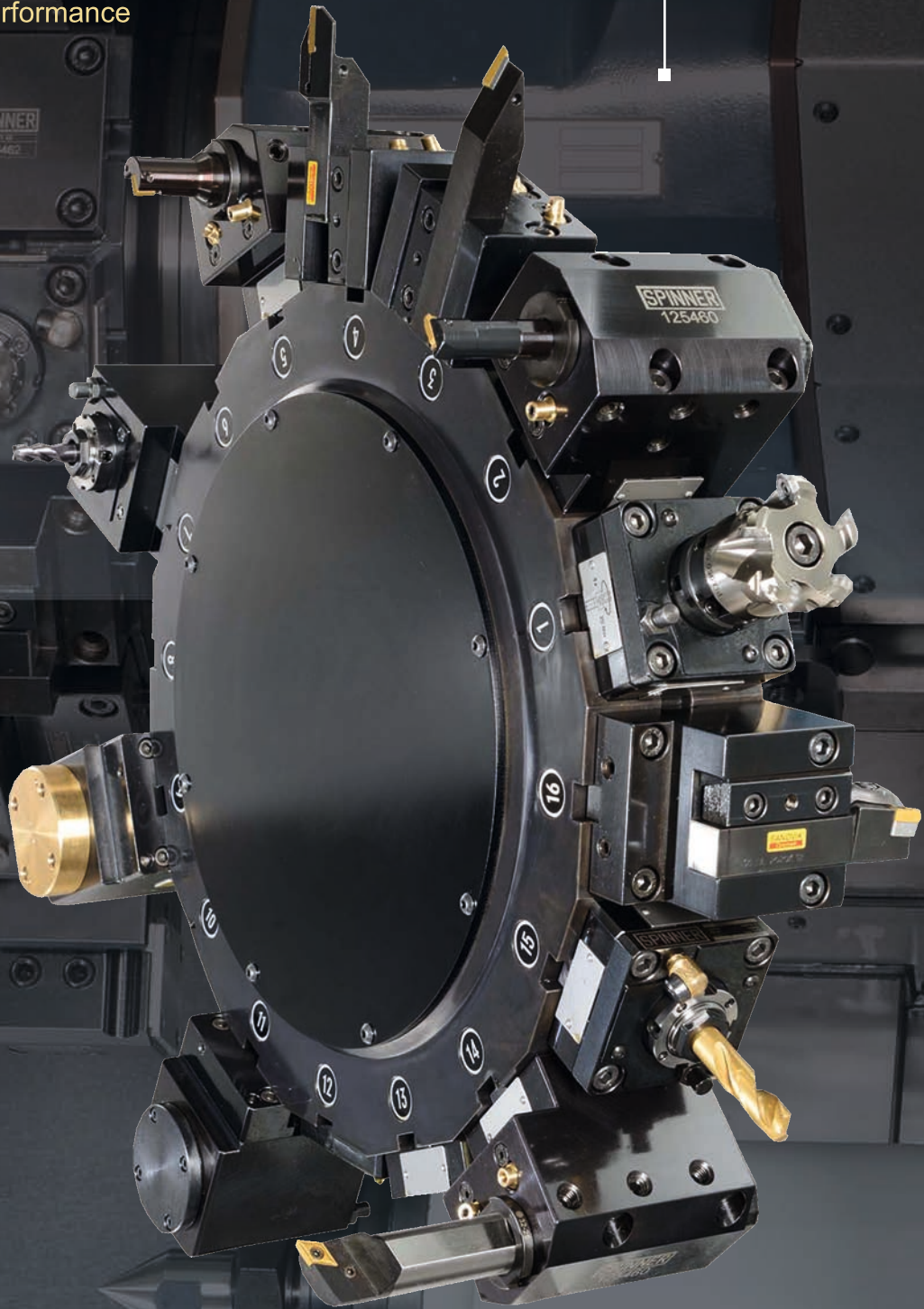

Figure shows turret disc BMT45, steady rest and CNC-tailstock

• Toolholder BMT45

Your advantages at one glance when using BMT45 toolholders

- High toolholder exchange precision
- No adjustment is required
- High stiffness
- Higher turning and milling performance



Air nozzle for compressed air on spindle

CNC-clamping force setting

Siemens 840D-SL
With Spinner 24-inch
Touch panel

Fanuc 32iT
With 15-inch screen

- Turret disc BMT45 16-position

- Toolholder package BMT45
- Hard turning package for superfinishing

- Workpiece measurement by touch probe in turret

- Suction unit for coolant mist
- Fire extinguishing system

External
tool measurement

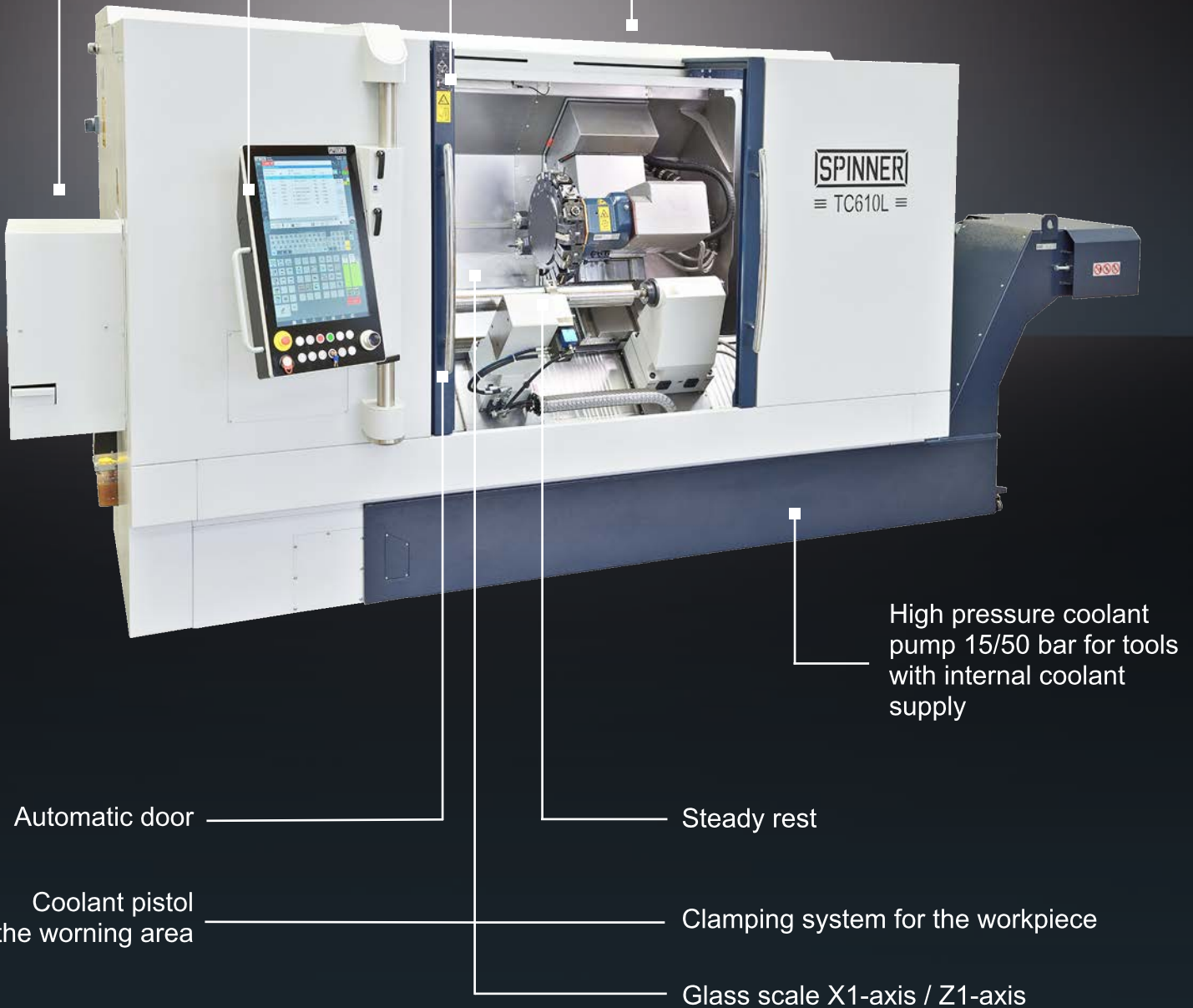

SPINNER
TC610L

High pressure coolant
pump 15/50 bar for tools
with internal coolant
supply

Automatic door

Steady rest

Coolant pistol
in the working area

Clamping system for the workpiece

Glass scale X1-axis / Z1-axis

Other options on demand

Automation solutions

Fully automated production solutions for large-scale production
FROM A SINGLE SOURCE from SPINNER and SPINNER-Automation



Your advantages at one glance

- Increase in productivity
- Cost reduction
- Optimal processes for your machining requirements
- Everything from one source



Ask us for your solution!

Working area	TC610L-65	TC610L-85
Swing diameter	600 mm	
Max. turning diameter	~400 mm	
Max. turning length	1,250 mm	
X1-axis / Z-axis	275 / 1350 mm	
Y-axis (option)	+50 / -40 mm	
Axes		
Rapide traverse X / Y / Z	30 / 30 m/min	
Spindle 1		
Max. spindle speed	4,000 1/min (option 5,000 rpm)	3,400 rpm (option 4,000 rpm)
Spindle nose	A8/DIN	A8/DIN
Chuck diameter	250 mm	250 mm (option 315 mm)
Spindle bore	65 mm	85 mm
Performance (100% / 40%)	18,5 / 24 kW	60 / 67 kW
Torque (100 % / 40%)	201 / 258 Nm	585 / 790 Nm
Tailstock		
Cone	MK4	
Stroke	~1,300 mm	
Turret		
Number of tool stations	16 (BMT45)	
Number of driven tools (option)	all	
Toolholder	BMT45	
Max. speed of driven tools	6,000 rpm	
Performance P_{max}	16,5 kW	
Torque M_{max}	35 Nm	
General indications		
Dimensions (L x W x H) ¹⁾	~3,400 x 1,950 x 2,100 mm	
Weight	from ~6,500 kg	

1) See floorplan

Main spindle TC610L-65 4,000 rpm

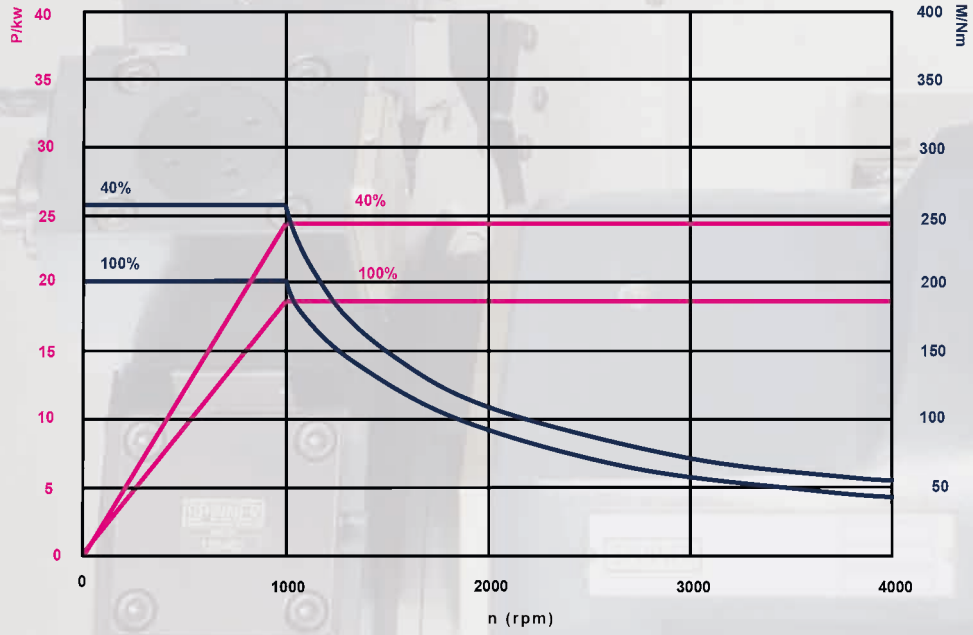

Main spindle TC610L-85 3,400 rpm

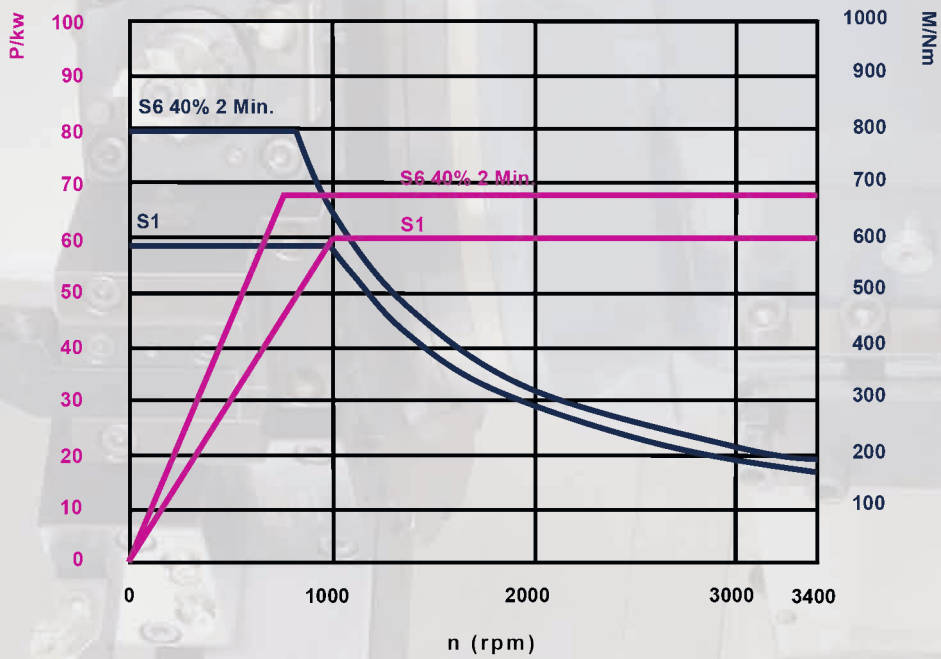

Driven tool

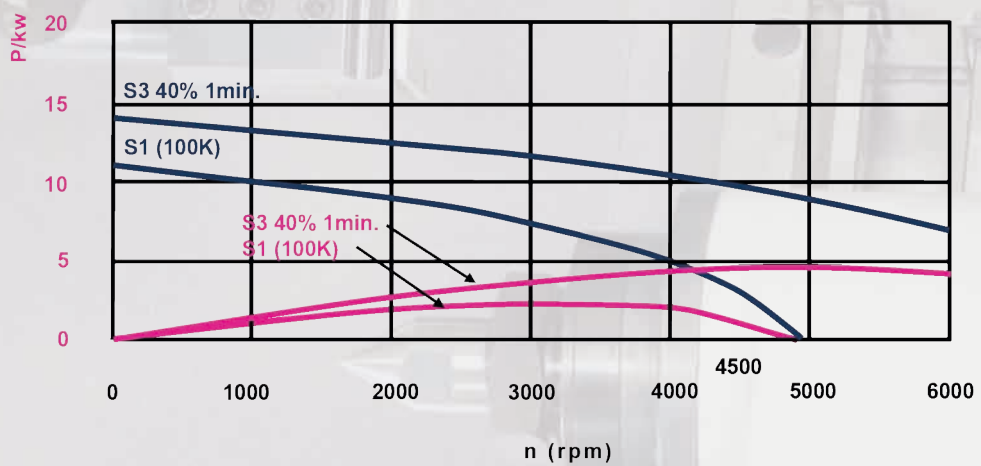

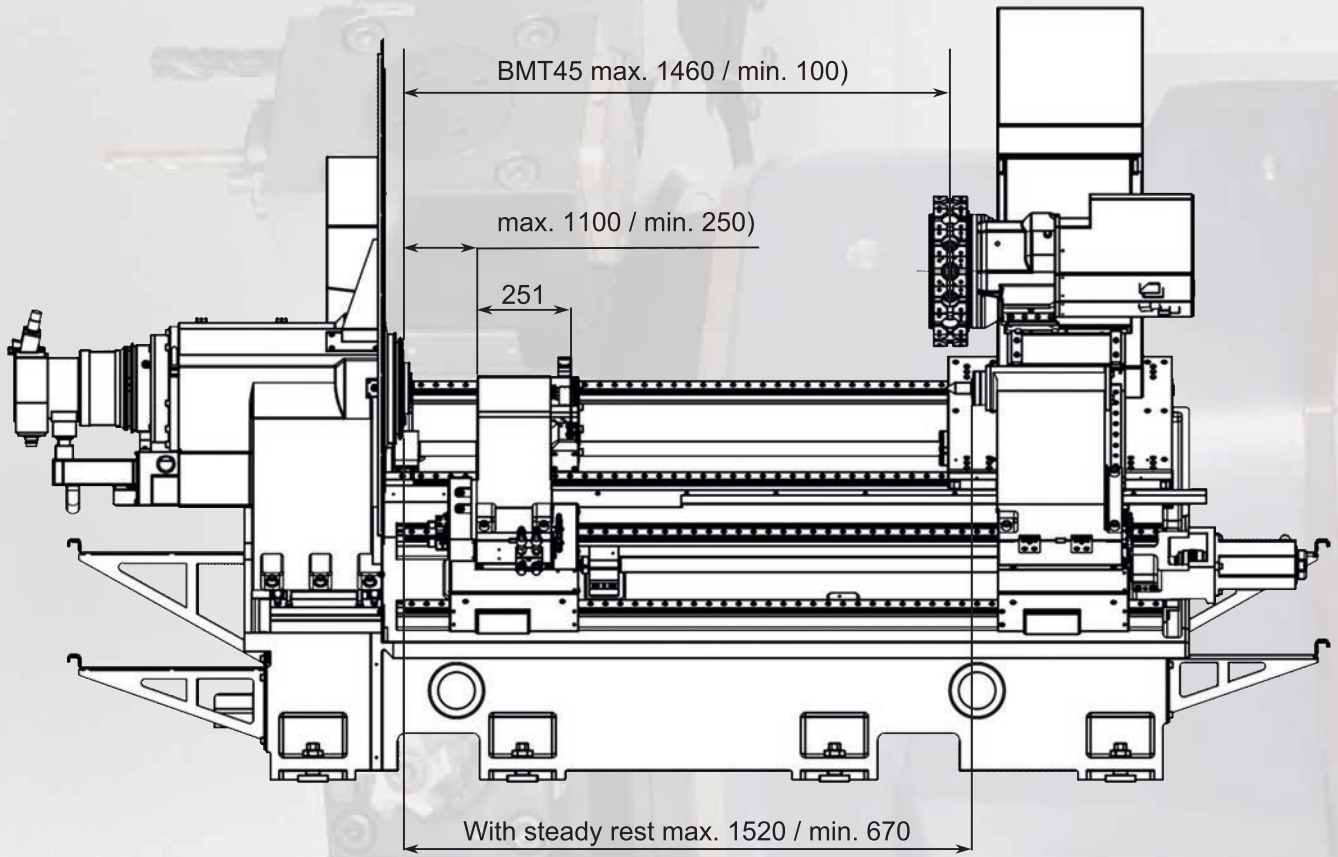

TC610L-MC

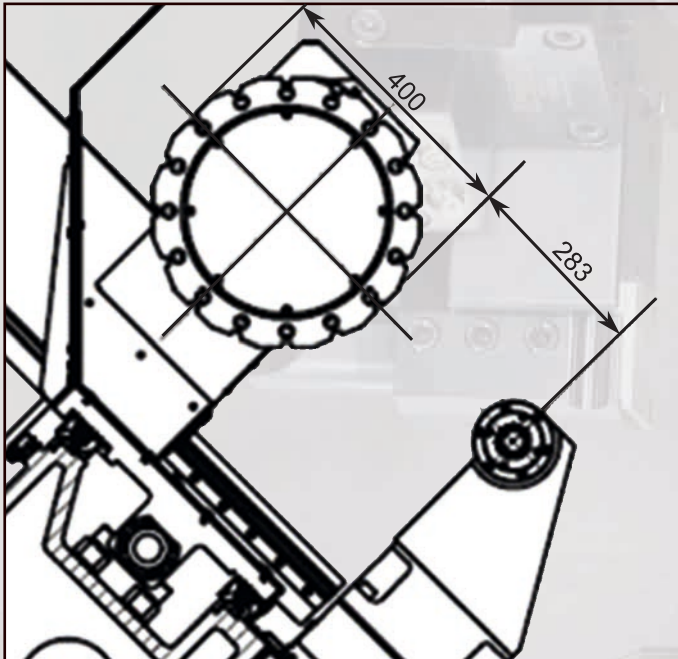

TC610L-MCY

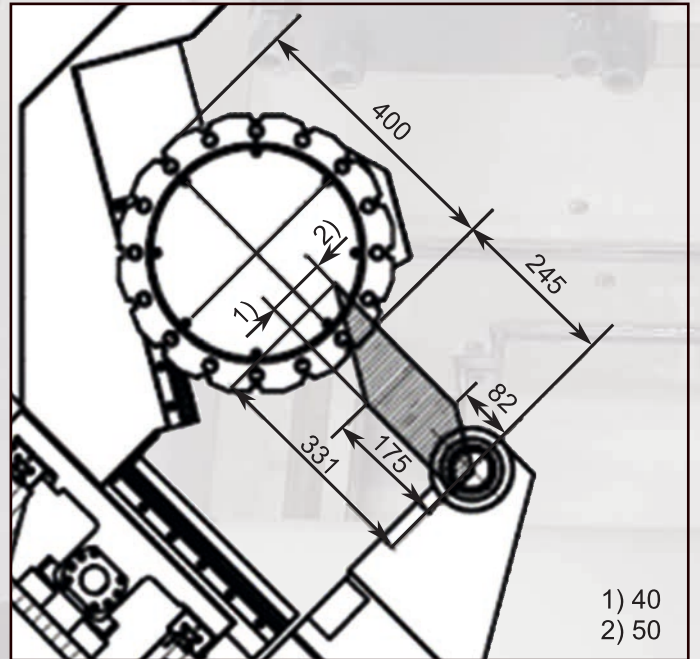

- 1) 40
- 2) 50

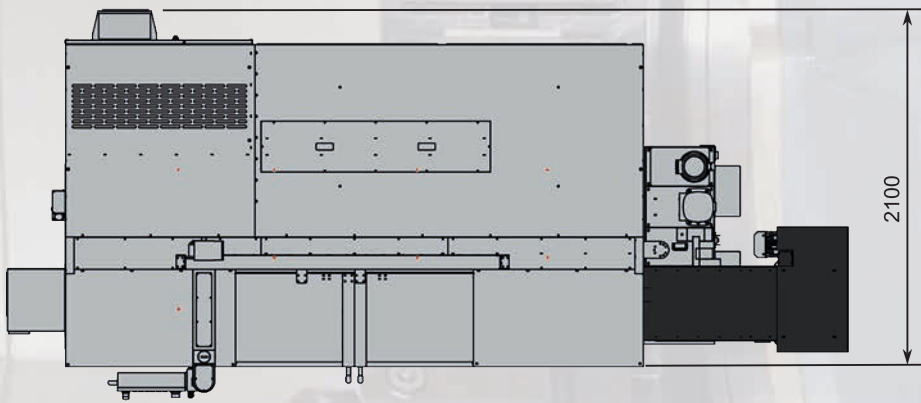
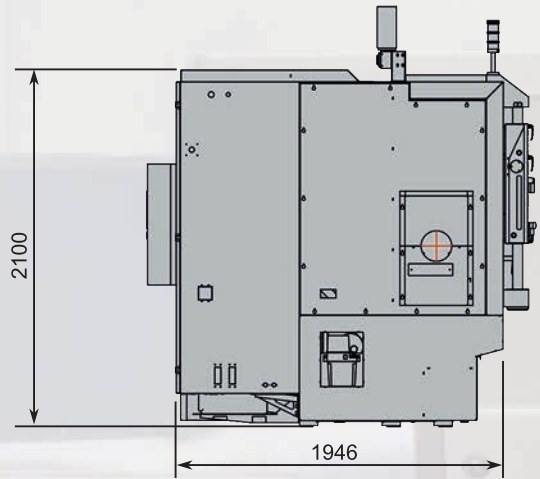
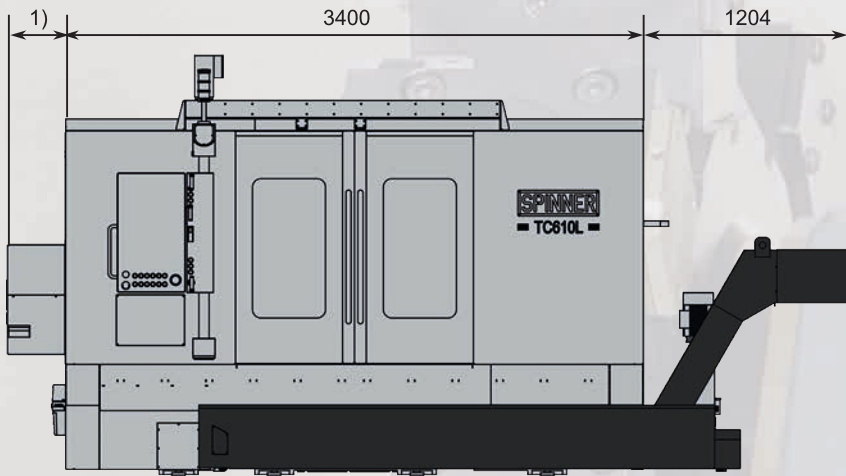

■ Version with standard chip conveyor

- 1) 184 TC610L-65
- 1) 344 TC610L-85

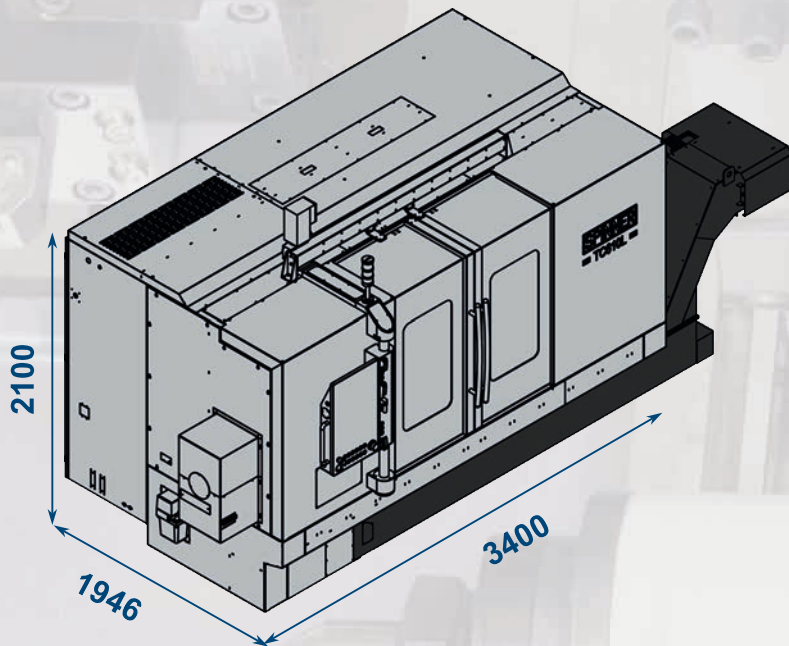

Compact dimensions for low space requirement



Werkzeugmaschinenfabrik GmbH



www.spinner.eu.com

Spinner Machine-Tools are working successfully world wide with many well known clients in more than 60 countries on 6 continents. We have been fortunate enough to attract small component suppliers in addition to well known global groups in all metal machining industries.

We have designed and produced the most modern machine-tools since 1950. More than 20.000 delivered machines demonstrate their high efficiency, precision and reliability, everyday.

Although Spinner is a medium-sized enterprise we produce and sell more than 1.000 CNC machines a year. And the number is increasing every year. Our company combines the know-how of a global player with the flexibility and cost-effective structures of a family owned business.

Place your trust in our products as well and let us know what we can do for you.



SPINNER Werkzeugmaschinenfabrik GmbH

Rudolf-Diesel-Ring 24

82054 Sauerlach

Tel. +49 (0) 8104 803-0

Fax +49 (0) 8104 803-19

sales@spinner.eu.com



Version 13.4.2023 (D)

Technical changes of specifications and pictures are subject to change without notice - Pictures can include options, accessories